



SCAN COMBIFLEX 450/450NS

MANUAL



SCANMASKIN
MACHINES-MINERALS-KNOW-HOW

Kære kunde!

Tak fordi du har valgt Scanmaskin som leverandør. Vi ønsker dig held og lykke med din nye Scan Combiflex 450 og håber, at den svarer til dine forventninger.

Scanmaskin Sverige AB



Claes-Göran Bergstrand
Administrerende direktør

Adresse:
Scanmaskin Sverige AB
Box 187
SE-437 22 Lindome / Göteborg
Sverige

Telefon: +46 (0) 31 99 49 70

Fax: +46 (0) 31 99 48 70

www.scanmaskin.se

<http://www.scanmaskin.com>

Denne brugermanual vedrører kun gulvslibemaskinen “**Scan Combiflex 450**” og “**Scan Combiflex 450NS**” herefter benævnt som “**SC-450**”. Ved specifik information og instruktioner til Scan Combiflex 450NS benævnes den maskine ”**SC-450NS**”. SC-450 må kun bruges til slibning af horisontale flader, som er godkendt af Scanmaskin Sverige AB.

Hvis SC-450 bruges til andre formål eller håndteres på en anden måde end beskrevet i denne brugermanual, så fraskriver Scanmaskin Sverige AB sig alt ansvar.

Bemærk kapitel ”2 Sikkerhedsforskrifter”. Læs brugermanualen inden gulvslibemaskinen SC-450 tages i brug. Reservedele og slibeværktøj som bruges til SC-450 skal være godkendt af Scanmaskin Sverige AB.

Indholdsfortegnelse

1	Specifikationer	2
1.1	Elektriske specifikationer	2
1.2	Mekaniske specifikationer	3
1.3	Værktøj	4
1.4	Anvendelsesområde	5
1.5	Indhold ved levering	5
1.6	Oversigt	6
2	Sikkerhedsforskrifter	8
2.1	Symbolforklaring	8
2.2	Sikkerhedsforanstaltninger	8
2.3	Organisationsforanstaltninger	9
2.4	Personale og kvalifikationer	10
2.5	Sikkerhed ved brug af maskinen	10
2.6	El-sikkerhed	11
2.6.1	Ledninger	13
2.6.2	Brug af generator	13
2.7	Definition af ”Slukket og sikker stilling”	13
2.8	Sikkerhed som vedrører service	14
2.9	Sikkerhed under transport	14
2.9.1	Manuel transport	14
2.9.2	Løftning	14
2.9.3	Inde i et køretøj	14
3	Transport	15
3.1	Sikkerhedsforanstaltninger	15
3.2	Manuel transport	15
3.3	Løftning	15
3.4	Deling af maskine	15
3.5	Inde i et køretøj	15
4	Håndtering	16
4.1	Forsigtighedsforanstaltninger	16
4.2	Maskinens funktion	16
4.3	Manøvregrab SC-450 Standard	17
4.4	Opstart	17
4.5	Stop	17
4.6	Kontrolpanel SC-450NS	18
4.6.1	Vandtank SC-450NS	19
4.7	Opstart SC-450NS	19
4.8	Nødstop / tilbagestilling SC-450NS	20
4.9	Stop SC-450 NS	20
4.10	Hastighedsregulering SC-450NS	20
4.11	Rotationsretning SC-450NS	20
4.12	Slukket og sikker stilling	20
4.13	Slibning	20
4.14	Værktøjsskift	21
5	Service	22
5.1	Sikkerhedsforanstaltninger	22
5.2	Daglig inspektion før brug	22
5.3	Service- og inspektionsskema	22

5.4	Skift af Scan-On-fæsteskive	23
5.5	Rengøring af maskinen	23
5.6	Fejlsøgning	23
5.6.1	Almindelige problemer	23
5.6.2	Alarm- og fejlkoder SC-450NS.....	24
6	Reservedele	25
6.1	Maskinhus.....	25
6.2	Centeraksel	26
6.3	Slibeaksel.....	27
6.4	Slibehoved	28
7	Garanti	28
8	EF-Deklaration	30
9	Alfabetisk register	31
10	Kontakt	32

1

1 Specifikationer

1.1 Elektriske specifikationer

For at finde de specifikationer som vedrører din maskine, ska du kontrollere informationskiltet som sidder fast på maskinens forside. (Se ”Figur 1-3” for mere information)



Tilslut aldrig SC-450 til andre forsyningsspændinger end beskrevet i denne specifikation.



Kraftkilden skal være afsikret ifølge ”Ekstern sikring” i denne specifikation. Ledningerne som bruges skal være mærket og godkendt til den brugte sikring. Det kan medføre brand eller skader, hvis der bruges forkerte sikringer.

Forsyningsalternativer	230 V 1~ ¹	230 V 1~ ²	110 V 1~
Effekt	1,5 kW (2 hk)	2.2 kW (3 hk)	1,5 kW (2 hk)
Strøm	8.7 A	12 A	18.5 A
Spænding	200 – 240 V 1~	200 – 240 V 1~	100 – 130 V 1~
Frekvens	50 Hz +/- 5%	50 Hz +/- 5%	60 Hz +/- 5%
Ekstern sikring ³	10 A	10 A	20 A
El-indtag ⁴	CEE 7/7 – 250V 16A + PE	CEE 7/7 – 250V 16A + PE	NEMA 5-20 – 125V 20A + PE

Tabel 0-1 Elektriske specifikationer

Alle modeller er CE-mærket.



Hvis der bruges en generator, læs ”2.6.2 Brug af generator”



¹ Standard

² 2,2kW motor / NS model

³ Vedrører sikringen i kraftkilden, f.eks. strømtavlen.

⁴ Dette er standardindtaget som medfølger. Maskiner som er solgt uden for EU sendes enten med et lokalt indtag eller en adapter.

1.2 Mekaniske specifikationer

Model	SC-450 Standard	SC-450 NS
Realiseringsdiameter	450 mm	450 mm
Slibeskivernes diameter	150 mm	150 mm
Slibeskivernes omdrejningstal	950 omdrejninger/min	300-1000 omdrejninger/min
Vægt	90 kg	100 kg
Slibehoved	Frigående 	Frigående 

Tabel 0-2 Mekaniske specifikationer

Dimensioner på SC-450

Bredde	460 mm
Højde	1030 mm
Dybde	810 mm

Dimensioner på fragtkasse

Bredde	610 mm
Højde	1430 mm
Dybde	810 mm

Omgivelsestemperatur under drift	-20°C til +40°C
Omgivelsestemperatur under opbevaring	-20°C til +70°C



Figur 1-1 Standard SC-45



Figur 1-2 SC-450NS

1.3 Værktøj



Maskinen skal udstyres med værktøj som er godkendt af Scanmaskin Sverige AB inden den tages i brug.



Se "Slibeguiden" for information om tilgængelige værktøj og "4.14 Værktøjsskift" for information om hvordan man skifter værktøj.

Værktøjet sidder fast med Scan-On-systemet for nemt værktøjsskift.

Tilgængeligt værktøj

- Riveværktøj
- Diamantværktøj
- Sandpapir

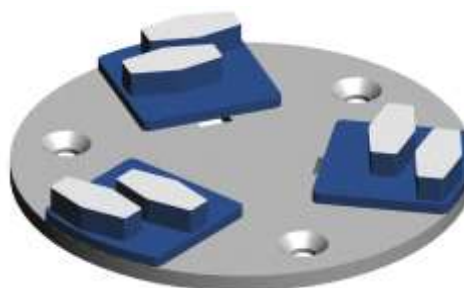

Figur 0-2 Scan-On-fæsteskrive med værktøj.

1.4 Anvendelsesområde



SC-450 er designet til horisontale flader. SC-450 må ikke bruges til andre formål end de, som er beskrevet i denne brugermanual. Producenten kan ikke holdes ansvarlig for materielle eller personskader, som er forårsaget af forkert brug af SC-450. Hvis brugermanualen ikke følges, erklæres garantien ugyldig.

Typiske anvendelsesområder

- Fjernelse af gamle belægninger, tæpper og spartel fra hårde flader
- Udglatning af betonflader
- Forberedelse til belægning på flader
- Polering af flader
- Fjernelse af belægningsdefekter
- Fjernelse af limrester

SC-450 anbefales til små til mellemstore arbejdsflader.

1.5 Indhold ved levering

Følgende er inkluderet med SC-450 ved levering.

- Brugermanual
- 5 mm unbrakonøgle

Maskiner som sælges uden for Europa vil enten være udstyret med et el-indtag som følger den lokale standard eller en passende kontaktfordobindelse som sidder i el-indtaget.



Læs "2.6 El-sikkerhed" inden medfølgende tilslutninger tilkobles.

1.6 Oversigt

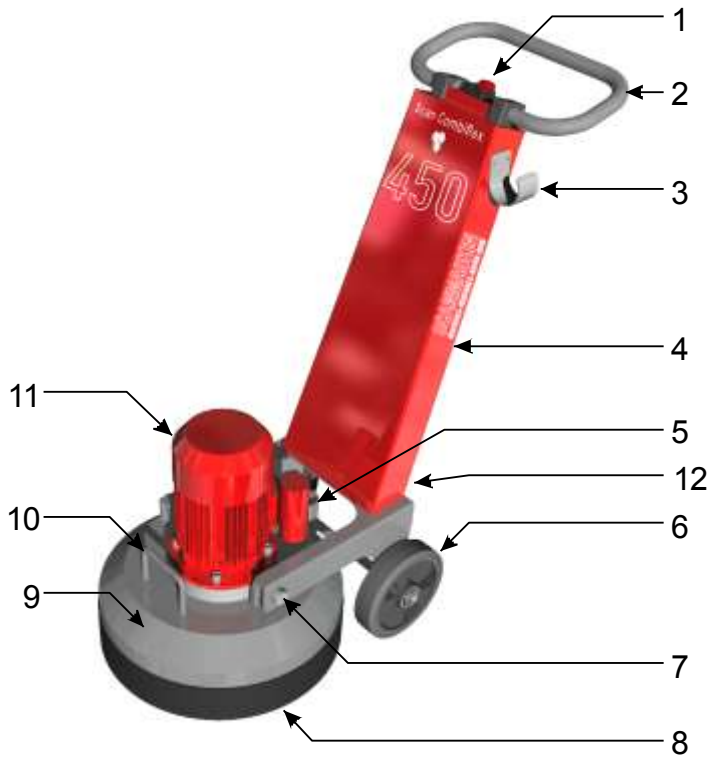

Figur 1-3 SC-450 oversigt

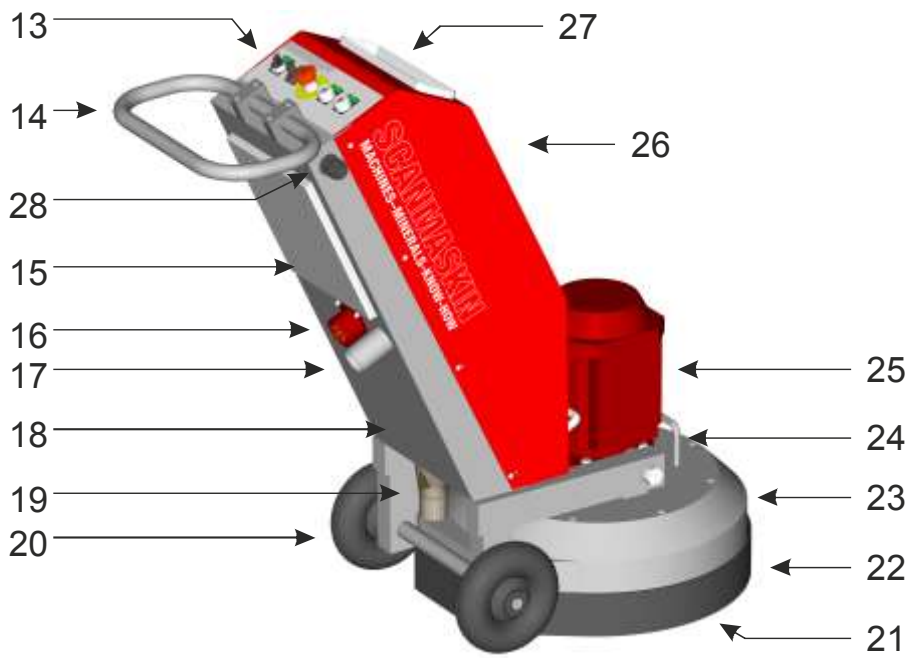

Figur 1-4 SC-450NS

Nummer	Beskrivelse	Reference
1	Manøvregreb	4.3 Manøvregreb
2	Håndtag	
3	Holder til støvsugerslange	
4	Vogn	
5	Støvsugerudtag	
6	Hjul	
7	Stift	
8	Støvbeskyttelse	
9	Slibehoved	4.14 Værktøjsskift
10	Løftehåndtag	3.3 Løftning
11	Motor	
12	Skillekontakt motor – vogn	
13	Kontrolpanel	
14	Håndtag	
15	El-skab	
16	El-indtag	
17	Støvsugertilslutning	
18	Chassis	
19	Nedre slange	
20	Hjul	
21	Maskinhus	
22	Støvbeskyttelse	
23	Beskyttelsesskærm	
24	Løftehåndtag	
25	Motor	
26	Skærm	
27	Vandtank	

Tabel 0-3 Oversigt over maskindele

2 Sikkerhedsforskrifter



Læs hele dette kapitel nøje igennem! Hvis sikkerhedsforskrifterne ikke læses, kan det medføre personskader eller materielle skader.

2.1 Symbolforklaring

	Sikkerhedsnotat
	El-sikkerhedsnotat
	Transportsikkerhedsnotat
	Tipningsrisiko
	Reference til mere information

2.2 Sikkerhedsforanstaltninger



Alle maskiner som ikke bruges ifølge sikkerhedsforskrifterne kan være farlige at bruge, indstille eller udføre service på. Arbejdslederen er ansvarlig for at sikkerhedsforskrifterne følges, både under brug og service af maskinen samt at sikkerhedsfunktioner som følger med maskinen bruges. Arbejdslederen er også ansvarlig for at stille passende øvrigt sikkerhedsudstyr til rådighed!

Beskyttelsesbriller og høreværn skal bæres hele tiden.

Maskinen må kun startes i oprejst stilling.

Sørg for at der ikke ligger affald på arbejdsfladen.

Undersøg arbejdsfladen for skruer eller andre hårde genstande som sidder i fladen. Brug ikke maskinen hvis der sidder fremmede genstande fast i fladen. Disse genstande skal fjernes inden maskinen bruges.



Læs "2.3 Organisationsforanstaltninger" og "2.5 Sikkerhed ved brug af maskinen" nøje igennem inden maskinen tages i brug!

2.3 Organisationsforanstaltninger



Brugermanualen skal opbevares i nærheden af det sted hvor maskinen bruges og skal hele tiden være inden for rækkevidde.

Udover denne brugermanual så skal almene og lovbestemte foranstaltninger angående ulykkesforhindring og miljøbeskyttelse følges såvel som de lokale forskrifter.

Sådanne foranstaltninger kan f.eks. vedrøre hvordan farlige substanser håndteres eller at tilbyde og bære beskyttelsesudstyr.

Denne brugermanual skal kompletteres af andre instruktioner inkluderet opgaven at overvåge og rapportere uheld, som relaterer til specielle arbejdsmetoder, f.eks. organisation, arbejdsrutiner og personalets sikkerhed.

Personale som er blevet udpeget til at arbejde med maskinen skal læse brugermanualen inden arbejdets påbegyndelse, især “2 Sikkerhedsforskrifter”. Det er for sent at læse manualen efter arbejdets påbegyndelse. Dette gælder især mindre aktiviteter som at indstille udstyret, udføre servicearbejde eller at uddanne personale til arbejde med maskinen.

Af og til skal arbejdet som maskinførerne udfører kontrolleres af en overordnet, især når det vedrører ting som relaterer til bevidsthed om sikkerhed og risici.

Maskinførerne skal samle og binde langt hår op og må ikke bære løst siddende tøj eller smykker (også ringe). Der foreligger en skaderisiko hvis genstande sætter sig fast i eller trækkes ind i bevægelige dele.

Beskyttelsesbriller og høreværn skal bæres hele tiden!

Brug personligt beskyttelsesudstyr hvis det er nødvendigt eller kræves af de lokale forskrifter.

Hvis der opdages en skade på maskinen som påvirker sikkerheden eller hvis arbejdsmetoden ændres, så at sikkerheden påvirkes, skal maskinen omgående slukkes. Problemet skal afhjælpes inden maskinen tages i brug igen.

Tillæg eller ændringer på maskinen som kan påvirke sikkerheden må ikke udføres uden producentens tilladelse!

Dette gælder især fastgørelse og justering af sikkerhedsanordninger.

Reservedele skal klare de tekniske krav, som er specificeret af producenten. Dette er altid garanteret, hvis der bruges originalreservedele.

Tidsintervaller for tilbagevendende kontroller i denne brugermanual skal følges!

For at kunne udføre servicearbejde på korrekt måde skal de rigtige værktøj bruges til formålet.

Reparationer må kun udføres af Scanmaskin Sverige ABs certificerede serviceteknikere.

Under visse forhold kan slibearbejde forårsage gnister. Personale som arbejder med maskinen skal derfor være bevidste om brandrisikoen og hvordan man håndterer en brandulykke på korrekt måde.

Brug ikke maskinen i områder med meget brandfarlige stoffer og/eller eksplosive stoffer.

2.4 Personale og kvalifikationer

Ansvarsområder:

- Servicearbejde må kun udføres af uddannet personale.
- Tydeliggør ansvarsområderne for personale som kører, indstiller eller udfører service.
- Sørg for at det kun er kompetent personale som bruger eller udfører service på maskinen.
- Definer maskinførerens ansvar med hensyn til trafiksikkerhedsregler og informere denne om ikke at tage imod instruktioner fra tredje part som eventuelt ikke følger de lokale sikkerhedskrav.
- Personale som uddannes til at bruge udstyret skal være under overvågning af en erfaren person!
- Arbejde på elektrisk udstyr må kun udføres af en autoriseret elektriker eller uddannet personale under overvågning af en autoriseret elektriker og arbejdet skal være i overensstemmelse med de lokale el-sikkerhedsforskrifter.

2.5 Sikkerhed ved brug af maskinen



Tillad ingen arbejdsmetode som forhindrer sikkerhedsforanstaltninger!

Anerkendte og officielle metoder skal bruges til at sikre at maskinen bruges på en sikker måde og bedste vilkår.

Brug kun maskinen når alle sikkerhedsanordninger og relateret sikkerhedsudstyr er tilstede og funktionsdygtige!

Kontrollér maskinen visuelt for skader eller defekter mindst en gang om dagen.



Se “5.2 Daglig inspektion før brug”

Hvis maskinen ikke fungerer på korrekt måde, skal den omgående slukkes!

Afspær arbejdsfladen omkring maskinen på offentlige steder og sørg for at der opretholdes en sikkerhedsafstand på mindst 10 meter fra maskinen.

Fejl skal omgående afhjælpes.

Tænd og sluk for maskinen i overensstemmelse med denne brugermanual.

Inden maskinen tændes skal man sørge for at ingen kan blive udsat for fare, når maskinen starter.

Maskinen må kun startes i oprejst stilling.

Sluk ikke og fjern ikke ventilationsrelaterede anordninger når maskinen er i gang!

Alle personer i maskinens nærhed skal bære høreværn, beskyttelsesbriller og sikkerhedssko. Udover dette skal maskinføreren bære tætsiddende beskyttelsestøj.

Forlængerledninger skal være mærket og godkendt til maskinens totale el-forbrug og følge almene og lokale bestemmelser.



Se også "2.6 El-sikkerhed".

Sørg for at der ikke ligger affald på arbejdsfladen.

Undersøg arbejdsfladen for skruer eller andre hårde genstande som sidder i fladen. Brug ikke maskinen hvis der sidder fremmede genstande fast i fladen. Disse genstande skal fjernes inden maskinen bruges.

2.6 El-sikkerhed



Kraftkilden skal være udstyret med sikringer ifølge “1.1 Elektriske specifikationer”. Forlængerledninger skal være mærket og godkendt til maskinens totale el-forbrug og følge almene og lokale bestemmelser. Tilslut aldrig maskinen til en kraftkilde som ikke har beskyttelses-jord!

Arbejde på elektrisk udstyr må kun udføres af en autoriseret elektriker eller uddannet personale under overvågning af en autoriseret elektriker i overensstemmelse med de lokale el-sikkerhedsforskrifter.

Forlængerledninger skal være mærket og godkendt til maskinens totale el-forbrug og følge almene og lokale bestemmelser.

Det elektriske udstyr på arbejdsstedet skal efterses regelmæssigt. Defekter som løse forbindelser eller brændte ledninger skal omgående afhjælpes. Kontakt en elektriker eller kundetjenesten.

Arbejdsområdet skal afspærres for tredje part. Følg de lokale el-sikkerhedsforskrifter når der udføres arbejde på maskinen. Efterlad aldrig en maskine uden opsyn. Brug kun isoleret værktøj.

Påbegynd kun arbejdet hvis du har kendskab til de lokale el-sikkerhedsforskrifter.

Kontrollér at spændingen er korrekt ifølge “1.1 Elektriske specifikationer” inden maskinen tændes.

2.6.1 Ledninger



Brug kun ledninger som er mærket og specificeret ifølge specifikationerne i "1.1 Elektriske specifikationer". Brug ikke for lange ledninger. Hvis der er brug for en lang tilslutning, så anbefaler vi en ledning til højere strøm som går til en strømtavle nær maskinen. Læg aldrig ledningen i en ring da den kan overhedes. Se "Figur 2-1".

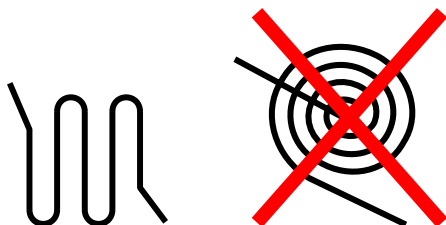

Figur 2-1 Anbefalinger til hvordan lange ledninger bruges.

2.6.2 Brug af generator



Generatoren skal være udstyret med beskyttelsesjord og bruges ifølge de nuværende EN-VDE-direktiver (dette hentyder især til beskyttelsesjord-tilslutningen) for at sikre at alle sikkerhedsanordninger virker og eliminere potentiel skade på elektriske komponenter.

2.7 Definition af "Slukket og sikker stilling"

Maskinen er i en sikker stand, når den ikke kan udgøre en fare.

Hvordan man omstiller maskinen til "Slukket og sikker stilling"

1. Sluk for maskinen
2. Hvis der bruges en støvsuger, skal den slukkes
3. Vent til alle bevægelige dele er standset helt
4. Frakobl hovedstrømmen
5. Du skal forsikre dig, at der ikke kan forekomme utilsigtet start



Frakobl altid hovedstrømmen til maskinen ved maskinen for at forhindre at en person utilsigtet tilkobler hovedstrømmen, mens der udføres arbejde på maskinen.

2.8 Sikkerhed som vedrører service

Sæt maskinen i slukket og sikker stilling inden der påbegyndes arbejde på maskinen.



Læs "2.7 Definition af "Slukket og sikker stilling"".

Arbejd aldrig på maskinen når hovedstrømmen er tilsluttet! Alle dele skal være standset helt inden arbejde påbegyndes!



Når maskinen ligger ned bagud, kan den vippe tilbage til dens oprejste stilling. Vær nøje med at forhindre at dette sker, så der ikke sker personskader eller materielle skader.



Når maskinen har været brugt, så kan segmenterne, Scan-On-fæsteskiverne og andre dele af maskinen være varme. Udvis forsigtighed for at forhindre forbrændinger.



Maskinen må ikke være tilkoblet en strømkilde, når den vaskes.



Se også "5.5 Rengøring af maskinen".

2.9 Sikkerhed under transport



Tag altid værktøjet af inden transport da de kan falde af eller forårsage skade på underlaget.

2.9.1 Manuel transport



Når maskinen transporteres manuelt skal man være opmærksom på skråninger og kanter. Følg arbejdspladsens lokale færdselsregler for at undgå ulykker. Hvis disse regler ikke følges, kan det medføre personskade eller materielle skader.

2.9.2 Løftning



Maskinen skal sikres ifølge de lokale sikkerhedsregler inden den løftes. Der må ikke opholde sig nogen under en løftet maskine! Maskinen skal løftes i overensstemmelse med instruktionerne i "3.3 Løftning". Vær opmærksom på maskinens tyngdepunkt inden den løftes. Hvis disse regler ikke følges, kan det medføre personskade eller materielle skader. Brug kun remme og stropper som er godkendt til den korrekte vægt og løftemetode!

2.9.3 Inde i et køretøj



Maskinen skal sikres ifølge de lokale transportsikkerhedsforskrifter inden maskinen transporteres inde i et køretøj. Hvis maskinen ikke sættes fast, kan det medføre personskade eller materielle skader.

3 Transport

3.1 Sikkerhedsforanstaltninger



Læs "2.9 Sikkerhed under transport" inden transport af maskinen påbegyndes.

3.2 Manuel transport

- Frigør værktøjet ifølge instruktionerne i "4.14 Værktøjsskift".
- Tryk håndtaget ned så slibehovedet løfter ca. 10 cm fra jorden.
- Før maskinen i den ønskede retning.

3.3 Løftning



Inden løft af maskinen påbegyndes, læs "2.9.2 Løftning".

- Frigør værktøjet ifølge instruktionerne i "4.14 Værktøjsskift".
- Sæt de remme som bruges til at løfte maskinen fast ved de to løftepunkter som vises i "Figur 3-1".
- Løft maskinen.



Figur 3-1 Løftepunkter SC-450 standard

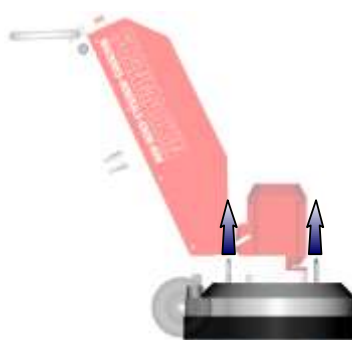

Figur 3-2 Løftepunkter SC-450 NS

3.4 Deling af maskine

Hvis maskinen skal transporteres i et trangt sted kan den deles i to dele. På hver side af motordelen er der to stifter som igen har hver sin hårnålestift. For at dele maskinen skal motoren først frakobles ved skillekontakten, tag derefter hårnålestifterne ud og derefter stifterne ud. Vær forsigtig så vognen ikke falder bagud.

3.5 Inde i et køretøj

- Frigør værktøjet ifølge instruktionerne i "4.14 Værktøjsskift".
- Sikr maskinen inde i køretøjet.



Sikr maskinen ifølge de lokale sikkerhedsforskrifter.

4 Håndtering

4.1 Forsigtighedsforanstaltninger



Alle maskiner som ikke bruges ifølge sikkerhedsforskrifterne kan være farlige at bruge, indstille eller udføre service på. Arbejdslederen er ansvarlig for at sikkerhedsforskrifterne følges, både under brug og service af maskinen samt at sikkerhedsfunktioner som følger med maskinen bruges. Arbejdslederen er også ansvarlig for at stille passende øvrigt sikkerhedsudstyr til rådighed!

Brug aldrig maskinen uden korrekt værktøj.

Beskyttelsesbriller og høreværn skal bæres hele tiden.

Maskinen må kun startes i oprejst stilling.

Sørg for at der ikke ligger affald på arbejdsfladen.

Undersøg arbejdsfladen for skruer eller andre hårde genstande som sidder i fladen. Brug ikke maskinen hvis der sidder fremmede genstande fast i fladen. Disse genstande skal fjernes inden maskinen bruges.



Læs "2 Sikkerhedsforskrifter" inden maskinen tages i brug.

4.2 Maskinens funktion

Gearhuset har tre slibeskiver som roterer i gearhusets modsatte retning. Hver slibeskive er udstyret med en Scan-On-fæsteskive som holder værktøjet som bruges. Se "Figur 4-1".



Figur 4-1 Illustrerer hvordan slibeskiverne bevæger sig i forhold til slibehovedet.



Maskinen er udstyret med en termisk beskyttelse som slukker motordriften ved høje temperaturer. Vent i mindst 15 minutter inden maskinen tages i brug igen!

4.3 Manøvregrab SC-450 Standard

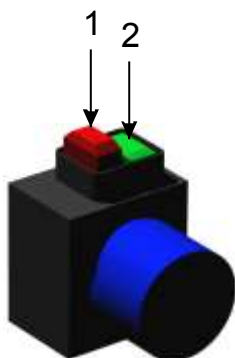

Figur 4-2 SC-450 Standard manøvregrab

Nummer	Funktion	Beskrivelse
1	Stop	Standser SC-450
2	Start	Starter SC-450

Tabel 4-1 Beskrivelse af manøvregrab

4.4 Opstart



Læs "4.1 Forsigtighedsforanstaltninger" inden maskinen startes.

Hvordan man starter maskinen

- Sørg for at maskinen er udstyret med korrekt værktøj
- Sørg for at hovedstrømmen og slanger til støvsuger er tilsluttet til maskinen
- Hvis der bruges en støvsuger, skal den startes
- Tryk håndtaget ned så slibehovedet løftes ca. 10 cm fra arbejdsfladen
- Tryk på startknappen (2)
- Sænk slibehovedet ned mod arbejdsfladen
- Slip aldrig håndtaget når maskinen er i drift

4.5 Stop

Hvordan man standser maskinen

- Tryk på stopknappen (1)
- Vent til maskinen er standset helt inden håndtaget slippes
- Hvis der bruges en støvsuger, skal den slukkes

4.6 Kontrolpanel SC-450NS



Figur4-3 SC-450NS kontrolpanel

Nummer	Tekst	Beskrivelse	Artikelnummer
1	L/R	Vælger rotationsretning	596001
2	SPEED	Vælger hastighed ⁵	596009
3	EMERGENCY STOP	Nødstop	596003
4	STOP	Standser maskinen	596007
5	START	Starter maskinen	596006

Tabel 4-2 Beskrivelse af kontrolpanelet.

⁵ Se ”Fel! Hittar inte referenskölla.Fel! Hittar inte referenskölla.” for at se hvilke hastigheder der gælder for din maskine.

4.6.1 Vandtank SC-450NS



For at øge vandstrømmen drejes regulatoren venstre om. Regulatoren vil bevæge sig udad.



For at mindske vandstrømmen drejes regulatoren højre om. Regulatoren vil bevæge sig indad.



For hurtigt at stoppe vandstrømmen trykkes på knappen på regulatoren. Dette frigør regulatoren og en fjeder trækker den ind.



For at sikre at regulatoren er helt lukket spændes den en lille smule.

For at tømme tanken inden liggende transport indstilles regulatoren på maksimum og lad vandet løbe ud. Sørg for at tanken er tømt inden liggende transport.

Tøm tanken inden langtidsopbevaring.

4.7 Opstart SC-450NS



Læs ”4.1 Forsigtighedsforanstaltninger” inden maskinen startes.

Hvordan man starter maskinen

- Sørg for at maskinen er udstyret med korrekt værktøj
- Sørg for at hovedstrømmen og slanger til støvsuger og vand er tilsluttet til maskinen
- Hvis der bruges en støvsuger, skal den startes
- Tryk håndtaget ned så slibehovedet løftes ca. 10 cm fra arbejdsfladen
- Sørg for at ”EMERGENCY STOP” (3) er tilbagesluttet.
- Tryk på ”START” (5).
- Sænk slibehovedet ned mod arbejdsfladen
- Slip aldrig håndtaget når maskinen er i drift

Hvis maskinen har været nødstoppet så skal man trykke på ”STOP” (4) inden man starter den for at tilbageslutte den.

4.8 Nødstop / tilbagestilling SC-450NS

Brug nødstop til hurtigt at standse maskinen for at forhindre ulykker eller skader.

Tilbagestilling:

- Drej "EMERGENCY STOP" (3) i urets retning til den kører op.
- Tryk på "STOP" (4)

Maskinen er nu klar til at blive startet igen.

4.9 Stop SC-450 NS

Hvordan man standser maskinen

- Tryk på "STOP" (4)
- Vent til maskinen er standset helt inden håndtaget slippes.
- Sluk for støvsugeren hvis den bruges.

4.10 Hastighedsregulering SC-450NS

Brug "SPEED" (2) til at justere rotationshastigheden på slibeskiverne i de interval som beskrives i "1.1 Elektriske specifikationer".

4.11 Rotationsretning SC-450NS

Brug "L/R"-omskifteren (1) til at skifte rotationsretning på slibeskiverne. Maskinen standser og starter automatisk i den valgte retning.

4.12 Slukket og sikker stilling

Når der udføres arbejde på maskinen, enten servicearbejde eller værktøjsskift, så skal maskinen sættes i "Slukket og sikker stilling" Se "2.7 Definition af "Slukket og sikker stilling"" for mere information.

4.13 Slibning

Se "Slibeguiden" for instruktioner og information om slibning.

4.14 Værktøjsskift



Inden værktøj skiftes, læs "2.8 Sikkerhed som vedrører service".

Denne illustration viser hvordan man skifter værktøj



Figur 4-4 Hvordan man fæster slibesegmenterne på Scan-On-fæsteskiven

- 1 Sæt værktøjet ind i den bredeste ende
- 2 Træk værktøjet udad fra skiven
- 3 Værktøjet sidder nu fast på Scan-On-fæsteskiven

For at forsikre dig at værktøjet sidder på plads så kan der bruges en lille plasthammer til forsigtigt at banke værktøjet fast. Plasthammeren kan også bruges til at fjerne et værktøj som sidder fast.

5 Service

5.1 Sikkerhedsforanstaltninger

Sæt maskinen i ”slukket og sikker stilling” inden der påbegyndes arbejde på maskinen.



Se “2.7 Definition af ”Slukket og sikker stilling””.



Læs “2.6 El-sikkerhed” inden arbejde på maskinen påbegyndes.

Arbejd aldrig på maskinen når hovedstrømmen er tilsluttet!

Alle dele skal være standset helt inden arbejde påbegyndes!



Når maskinen ligger ned på bagsiden, kan den vippe tilbage til dens oprejste stilling. Vær nøje med at forhindre at dette sker, for at sikre at der ikke sker personskader eller materielle skader.



Når maskinen har været i brug, så kan segmenterne, Scan-On-skiverne og andre dele være varme. Vær forsigtig for at forhindre forbrændinger.

Indjustering, service- og inspektionsarbejde skal udføres af kvalificeret personale.



Maskinen må ikke have hovedstrømmen tilkoblet når den vaskes.

5.2 Daglig inspektion før brug

Kontrollér følgende ting inden maskinen tages i brug

- Kontrollér at hjulene ikke er beskadiget.
- Kontrollér slibehovedets skiver og nav for beskadigelse.
- Kontrollér slibehovedet, snavs som sidder mellem Scan-On-fæsteskiven og slibeskivenavet kan mindske slibehovedets fleksibilitet.
- Hvis skruer sidder løst skal de spændes.
- Se hele maskinen efter så der ikke er opstået anden skade.

5.3 Service- og inspektionsskema

Dagligt	<ul style="list-style-type: none"> ▪ Kontrollér hjulene ▪ Kontrollér slibehovedet ▪ Efterse maskinen for skader
12 timer efter service	<ul style="list-style-type: none"> ▪ Efterspænd samtlige skruer

5.4 Skift af Scan-On-fæsteskiye

Følg disse trin for at skifte Scan-On-fæsteskiye

- Sørg for at maskinen er sat i ”slukket og sikker stilling” som beskrevet i ”2.7 Definition af ”Slukket og sikker stilling””
- Læn maskinen bagud og sikr den.
- Fjern eventuelle værktøj ifølge ”4.14 Værktøjsskift”.
- Løsn de tre skruer som holder Scan-On-skiven fast.
- Skift Scan-On-fæsteskiye.
- Det anbefales at der bruges nye skruer til at sætte den udskiftede Scan-On-fæsteskiye fast.
- Det anbefales også at man bruger kobberpasta i forsænkningen.
- Skru alle skruer fast med hånden og sørg for at de er ordentligt spændt.

5.5 Rengøring af maskinen

Inden rengøring af maskinen påbegyndes skal man sørge for at den er i ”slukket og sikker stilling”.

Hovedstrømmen må ikke være tilsluttet til maskinen under rengøringen.

Brug ikke højtrykrenser til at rengøre maskinen. Vand og sæbe anbefales.

5.6 Fejlsøgning

5.6.1 Almindelige problemer

Symptom	Årsag	Afhjælpning	A ⁶
Maskinen startar ikke	<ul style="list-style-type: none"> ▪ Kraftkilden er strømløs 	<ul style="list-style-type: none"> ▪ Kontrollér sikringerne ved arbejdsstedets kraftkilde. ▪ Kontrollér ledningerne. ▪ Kontrollér at hovedstrømmen når frem til maskinen og har korrekt spænding. 	O E E
Maskinen kører kun når den grønne knap er trykket ned.	<ul style="list-style-type: none"> ▪ Motoren er overhedet 	<ul style="list-style-type: none"> ▪ Vent til motoren er kølet af 	O
	<ul style="list-style-type: none"> ▪ Styreboksen er blevet skadet 	<ul style="list-style-type: none"> ▪ Udskift styreboksen 	S
Maskinen er sløj og kan ikke så meget	<ul style="list-style-type: none"> ▪ Der er sket et spændingsfald 	<ul style="list-style-type: none"> ▪ Kontrollér sikringerne ved arbejdsstedets kraftkilde. ▪ Kontrollér ledningerne. ▪ Kontrollér at hovedstrømmen når frem til maskinen og har korrekt spænding. 	O E E
		<ul style="list-style-type: none"> ▪ Sørg for at der ikke er brugt for lange ledninger. Hvis der er brug for en meget lang ledning, så kan man bruge en ledning til højere strøm som går til en strømtavle nær maskinen. 	O
Maskinen vibrerer meget	<ul style="list-style-type: none"> ▪ Slibehastigheden er for høj 	<ul style="list-style-type: none"> ▪ Sænk hastigheden 	O
	<ul style="list-style-type: none"> ▪ Værktøjet er beskadiget 	<ul style="list-style-type: none"> ▪ Kontrollér værktøjet ▪ Udskift hvis nødvendigt 	O O

5.6.2 Alarm- og fejlkoder SC-450NS

Kode	Beskrivelse	Årsag	Afhjælpning	A ⁶
A2001	Overstrøm	<ul style="list-style-type: none"> En af de tre faser mangler fra strømkilden Der er sket et spændingsfald 	<ul style="list-style-type: none"> Kontrollér strømkildens sikringer Kontrollér ledningerne Kontrollér at hovedstrømmen når frem til alle faser og har korrekt spænding ved maskinen. Sørg for at ledningen ikke er for lang. Hvis der behøves en lang ledning, skal der bruges en grovere ledning og sættes et el-skab nærmere maskinen. 	O E E O
		<ul style="list-style-type: none"> Omgivelsestemperaturen er for høj. Når omgivelsestemperaturen er over 40°C så vil omformerens mindske den maksimale udgangsstrøm 	<ul style="list-style-type: none"> Kontrollér ventilatorerne Kontrollér ventilatorenes filter 	O O
A2002	Overspænding	<ul style="list-style-type: none"> Kraftkilden har spændingsspidser 	<ul style="list-style-type: none"> Kontrollér kraftkilden 	E
A2003	Underspænding	<ul style="list-style-type: none"> En af de tre faser mangler fra strømkilden Der er sket et spændingsfald 	Se A2001	
A2006	Hastighedsreferencefejl	<ul style="list-style-type: none"> Potentiometeret på kontrolpanelet er beskadiget 	<ul style="list-style-type: none"> Kontrollér potentiometeret Udskift hvis nødvendigt 	S S
A2009	Overhedning	<ul style="list-style-type: none"> Den interne temperatur overstiger 120°C. Dette kan skyldes nedsat ventilation i el-skabet. 	<ul style="list-style-type: none"> Kontrollér ventilatorerne Kontrollér ventilatorenes filter Kontakt Scanmaskin Sverige AB 	O O
A5001	Intern fejl	Kontakt Scanmaskin Sverige AB		
F0001	Overstrøm	Se A2001		
F0002	Overspænding	Se A2002		
F0003	Overhedning	<ul style="list-style-type: none"> Den interne temperatur overstiger 135°C. Dette kan skyldes nedsat ventilation i el-skabet. 	Se A2009	
F0004	Motoren kortsluttet	<ul style="list-style-type: none"> Motorens kabel er beskadiget. Motoren er beskadiget. 	<ul style="list-style-type: none"> Kontrollér motorens kabel Kontrollér konnektoren Kontakt Scanmaskin Sverige AB 	E E
F0006	Underspænding	Se A2003		
F0007	Hastighedsreferencefejl	Se A2006		
F0016	Jord(ings)fejl	<ul style="list-style-type: none"> Motorens kabel er beskadiget Motoren er beskadiget Der er kommet vand i motoren 	<ul style="list-style-type: none"> Kontrollér motorens kabel Kontrollér konnektoren Kontakt Scanmaskin Sverige AB 	E E
F0018	Intern fejl	Kontakt Scanmaskin Sverige AB		
F0021		Kontakt Scanmaskin Sverige AB		
F0022	Fasefejl	Se A2003		
F0034	Motorfasefejl	<ul style="list-style-type: none"> En af de tre faser til motoren mangler. Dette kan skyldes skade på motorkablet eller motoren. 	<ul style="list-style-type: none"> Kontrollér motorens kabel Kontrollér konnektoren Kontakt Scanmaskin Sverige AB 	E E

Tabel 5-1 Fejlkoder

Alarmkoder begynder med “A” og fejlkoder med “F”. Maskinen kan bruges ved en alarm, men ikke ved en fejl.

Følgende tabel beskriver hvem der må gøre hvad, når det drejer sig om servicearbejde.

Forkortelse	Person
O	Maskinfører
E	Elektriker
S	Scanmaskin certificeret servicetekniker

Tabel 5-2 Beføjelse til servicearbejde

6 Reservedele

6.1 Maskinhus

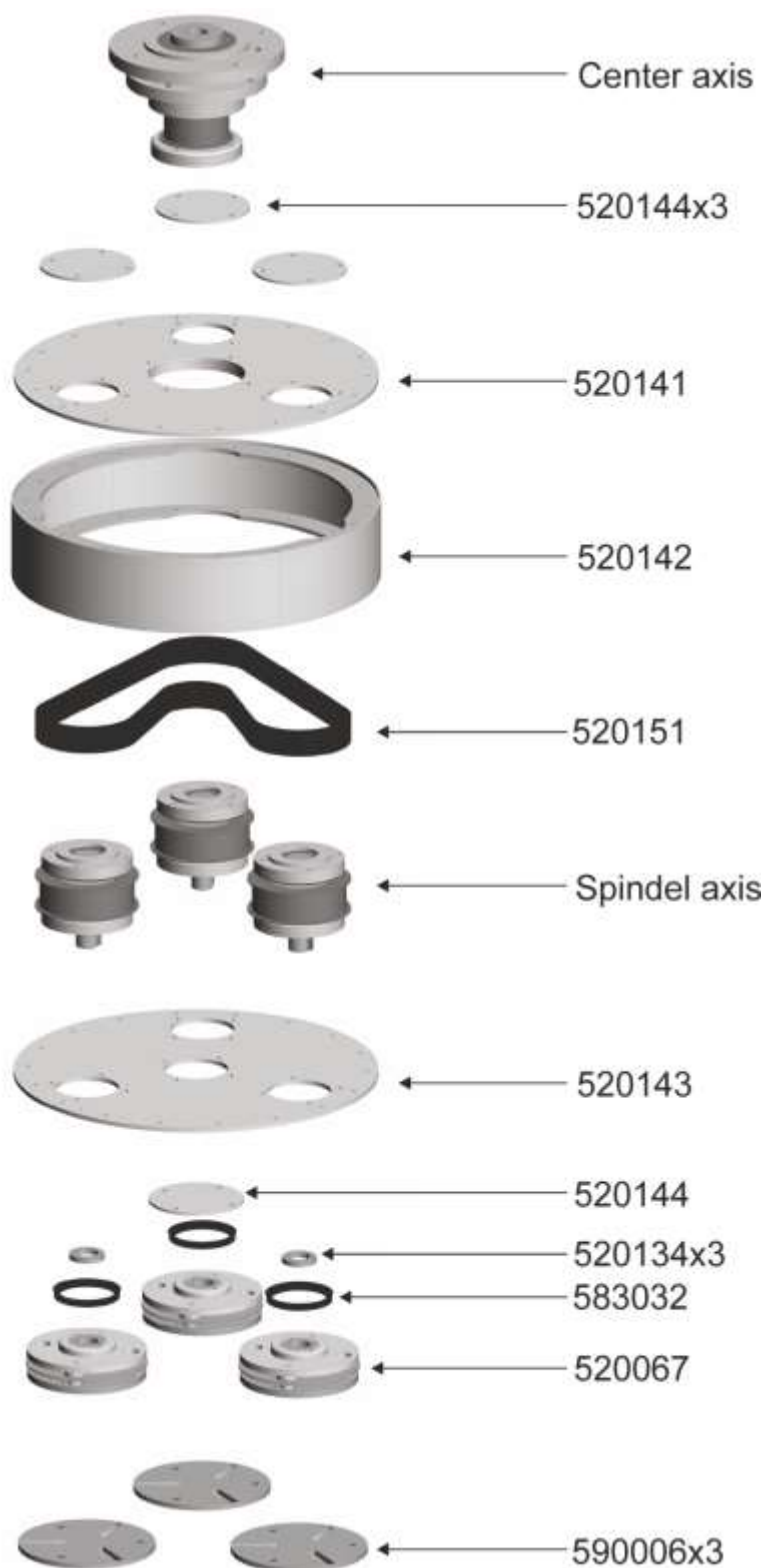

6.2 Centeraksel



6.3 Slibeaksel

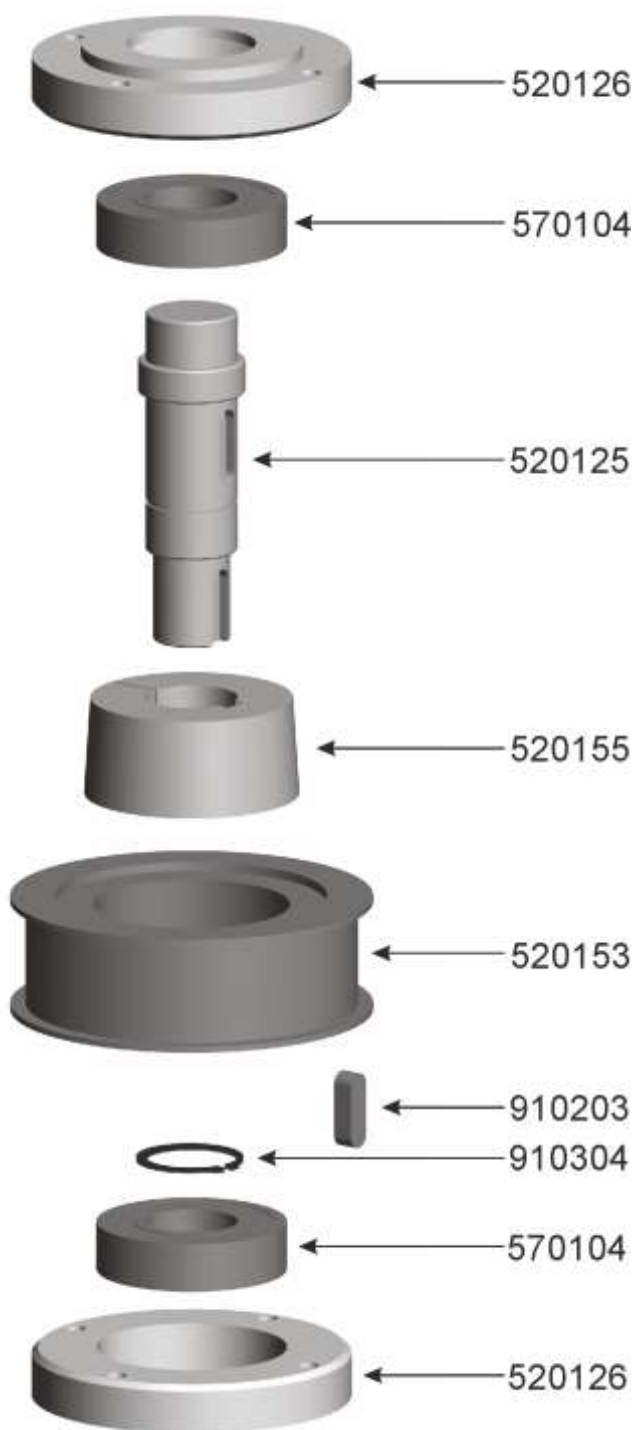

6.4 *Slibehoved*



7 Garanti

Dette produkt fra Scanmaskin Sverige AB har tolv måneders garanti.

Hvis produktet ikke skulle fungere tilfredsstillende inden for denne tid, vil Scanmaskin sørge for, at produktet gøres funktionsdygtigt til den normale anvendelse, som produktet er tiltænkt – uden omkostninger til arbejde eller reservedele, i henhold til følgende vilkår:

1. Garantien gælder kun personer, som lovligt har ejendomsret til udstyret i garantiperioden.
2. Producentens ansvar er begrænset til reparation af defekte dele eller udskiftning af disse efter producentens bedømmelse. Transportomkostninger og -risici, samt demontering og geninstallation af produktet/produkterne, samt andre direkte eller indirekte omkostninger, som hænger sammen med den aktuelle reparation, dækkes ikke af denne garanti.
3. Periodiske kontroller, justeringer, vedligeholdelsesarbejder og ændringer dækkes ikke af garantien.
4. Scanmaskin er ikke ansvarlig for eventuelle skader på slibeskiver eller andet lignende udstyr.
5. Garantien gælder udelukkende fejl i materialer og konstruktion og gælder ikke i følgende tilfælde:
 - a. Skader forårsaget ved ulykker, forsømmelighed, ændringer, anvendelse af reservedele eller slibeværktøjer, som ikke er originale dele/komponenter, eller forkert anvendelse og installation.
 - b. Skader forårsaget af lynnedslag, vand, brand, hærværk, forkert netspænding, forkert ventilation eller anden årsag, som ligger uden for producentens kontrol.
6. Scanmaskin forbeholder sig ret til at ændre konstruktionen eller foretage forbedringer uden pligt til at ændre tidligere fremstillede produkter.
7. Alle garantireparationer skal udføres af Scanmaskin eller af et Scanmaskin autoriseret reparationsværksted. Omkostninger til reparationer, som udføres af et ikke-godkendt værksted, erstattes ikke af Scanmaskin. Hvis en sådan reparation skulle medføre skade på produktet dækkes den ikke af garantien.

8 EF-Deklaration

EU-overensstemmelseserklæring

Producent Scanmaskin Sverige AB
Adresse Heljesvägen 10
427 36 Lindome / Göteborg
Sverige

Produkt Slibemaskine

Produktnavn Scan Combiflex 450
Scan Combiflex 450NS

Serienummer _____

Ovenstående produkt er i overensstemmelse med følgende EU-direktiver

Maskindirektiv 2006/42/EF
EMC 2004/108/EF
LVD 2006/95/EF
Harmoniserede standarder EN ISO 12100:2010
EN ISO 60204-1

Udstedelsessted Lindome / Göteborg / Sverige

Autoriseret repræsentant Claes-Göran Bergstrand
Administrerende direktør

Scanmaskin Sverige AB
01-01-2010

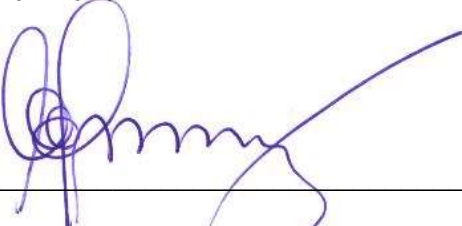

Claes-Göran Bergstrand
Administrerende direktør

9 Alfabetisk register

INDEX

10 Kontakt

Sverige Hovedkontor

Heljesvägen 10
Box 187
S-437 22 Lindome

Telefon: +46 (0) 31 99 49 70
Fax: +46 (0) 31 99 48 70
E-mail: info@scanmaskin.se
Hjemmeside: www.scanmaskin.se

Danmark

Torvegade 22
DK-7330 Brande

Telefon: +45 97 18 00 58
Fax: +45 97 18 45 58
E-mail: info@scanmineral.dk
Hjemmeside: www.scanmaskin.se

Norge

Postboks 6, Furuset, N-1001 Oslo
Tomtveien 12
N-2015 Leisund

Telefon: +47 -63 87 60 00
Fax: +47 -63 87 60 01
E-mail: info@scanmaskin.no
Hjemmeside: www.scanmaskin.no

Finland

Raudoittajantie 3A
FIN-06450 Porvoo / Borgå

Telefon: +358 10 292 4700
E-mail: info@scanmaskin.fi
Hjemmeside: www.scanmaskin.fi

USA

1407 132nd Avenue Northeast, Suite 8
Bellevue, Washington, 98005

Phone: +1 425 209 0147
E-mail: info@scanmaskin.com
Hjemmeside: www.scanmaskin.com

Dear Customer!

Thank you for choosing Scanmaskin as your supplier.
We wish you all the best with your new Scan Combiflex™ 450 and hope that it meets your expectations.

Scanmaskin Sweden AB



Claes-Göran Bergstrand
Managing Director

Address:

Scanmaskin Sweden AB

Box 187

SE-437 22 Lindome / Gothenburg

Sweden

Telephone: +46 (0) 31 99 49 70

Fax: +46 (0) 31 99 48 70

<http://www.scanmaskin.com/>

Important Information!

This User Guide only concerns the floor grinding machines “**Scan Combiflex 450**” hereby referred to as “**SC-450**”. SC-450 may only be used for grinding horizontal surfaces approved by Scanmaskin Sweden AB.

If SC-450 is used for other purposes or handled in ways other than that described in this User Guide, Scanmaskin Sweden AB disclaims all responsibility.

Especially note the section “2 *Safety Regulations*”. Read the User Guide before using the floor grinding machine SC-450. The spare parts, grinding discs used on SC-450 must be approved by Scanmaskin Sweden AB.

Table of Contents

1	Specifications.....	40
1.1	Electrical specifications.....	40
1.2	Mechanical specifications.....	41
1.3	Tools.....	42
1.4	Range of application.....	43
1.5	Scope of supply.....	43
1.6	Overview.....	44
2	Safety Regulations.....	46
2.1	Legend.....	46
2.2	Safety precautions.....	46
2.3	Organizational measures.....	47
2.4	Personnel selection and qualification.....	48
2.5	Safety regarding operation of machine.....	48
2.6	Electrical safety.....	49
2.6.1	Cables.....	50
2.6.2	Using a generator.....	50
2.7	Definition of the “Safety off position”.....	50
2.8	Safety regarding maintenance.....	51
2.9	Safety regarding transport.....	51
2.9.1	Manual transport.....	51
2.9.2	Lifting.....	52
2.9.3	Inside vehicles.....	52
3	Transportation.....	53
3.1	Safety precautions.....	53
3.2	Manual transportation.....	53
3.3	Lifting.....	53
3.4	Separation of machine.....	53
3.5	Inside vehicles.....	54
4	Operation.....	55
4.1	Precautions.....	55
4.2	Machine functions.....	55
4.3	Control device SC-450.....	56
4.4	Start up.....	56
4.5	Stop.....	56
4.6	Control panel SC 450 NS.....	57
4.6.1	Water tank SC-450 NS.....	57
4.7	Start up the SC-450 NS.....	58
4.8	Emergency stop / Reset SC-450 NS.....	58
4.9	Stop the SC-450 NS.....	58
4.10	Grinding speed SC-450 NS.....	58
4.11	Rotation direction SC-450 NS.....	58
4.12	Safety off position.....	59
4.13	Grinding.....	59
4.14	Changing tools.....	59
5	Maintenance.....	60
5.1	Precautions.....	60
5.2	Daily inspection prior to operation.....	60

5.3	Maintenance and inspection list	60
5.4	Grinding disc replacement / assembly	61
5.5	Cleaning the machine	61
5.6	Trouble shooting	61
5.6.1	Common faults	61
5.6.2	Error codes SC-450 NS	62
6	Spare parts	63
6.1	Gear barrel	63
6.2	Center axis	65
6.3	Spindel axis	67
6.4	Grinding head	69
7	Warranty	71
8	EU Declaration	72
9	Alphabetical reference	73
10	Contact information	74

1 Specifications

The SC-450 is available with different power inputs. This is described in the different sections later on in this chapter.

1.1 Electrical specifications

To find the specifications that apply to your machine, check the information plate on the machine.



Never connect the SC-450 to any other voltage or number of phases than described in this specification.



The power source must be fused according to “External fuse” in this specification; also the cables used must be marked and rated in accordance with the fuse used. Failure to comply with the correct fuses may cause fire or injuries.

Power choice ¹	230 V 1~ ²	230 V NS	110 V 1~
Power	1.5 kW (2 hp)	2.2 kW (3 hp)	1.5 kW (2 hp)
Current	8.7 A	12.9 A	18.5 A
Voltage	200 – 240 V 1~	200 – 240 V 1~	100 – 130 V 1~
Frequency	50 Hz +/- 5%	50 Hz +/- 5%	60 Hz +/- 5%
External fuse ³	10 A	13 A	20 A
Power inlet ⁴	CEE 7/7 – 250V 16A + PE	CEE 7/7 – 250V 16A + PE	NEMA 5-20 – 125V 20A + PE

Table 1-1 Electrical specifications

All models are CE-marked.



If using a generator see “2.6.2 Using a generator”

¹ This refers to different power choices. Note that a SC-450 made for one choice of power must be used with the particular choice.

² Standard

³ Maximum current for the fuses used in the power source (*i.e. the distribution box*).

⁴ This is the standard inlet used. Machines sold outside of EU will be shipped either with a local standard inlet or an adapter.

1.2 Mechanical specifications

Model	SC-450	SC-450 2,2 NS / 2.2kW
Grinding diameter	450 mm 17.7"	450 mm 17.7"
Grinding plate diameter	150 mm 5.9"	150 mm 5.9"
Grinding plate speed	950 rpm	950 rpm
Mass	90 kg 198 lbs	100kg 220 lbs
Gear barrel	Free running 	Free running 

Table 1-2 Mechanical specifications

Dimensions of SC-450

Width	460 mm	18.1"
Height	1030 mm	40.6"
Depth	810 mm	31.9"

Dimensions of shipping box

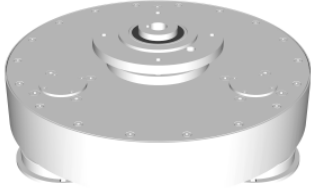
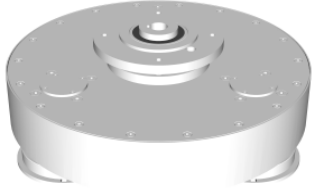
Width	610 mm	24.0"
Height	1430 mm	56.3"
Depth	810 mm	31.9"

Ambient temperature during operation	-20°C to +40°C	-4°F to 104°F
Ambient temperature during storage	-20°C to +70°C	-4°F to 158°F



Figure 1-1 Standard SC-450

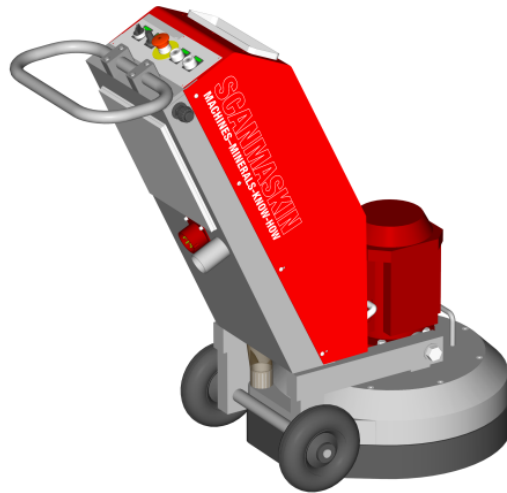

Figur 1-2 SC-450 NS

1.3 Tools



The machine must be equipped with tools approved by Scanmaskin Sweden AB before operation.



See “Grinding guide” for information about available tools and “4.14 Changing tools” for information about how to change the tools.

The tools are fitted using the Scan-On system for easy fitting.

Available tools

- Diamond tools
- SC-Tiger PCD
- Sand paper

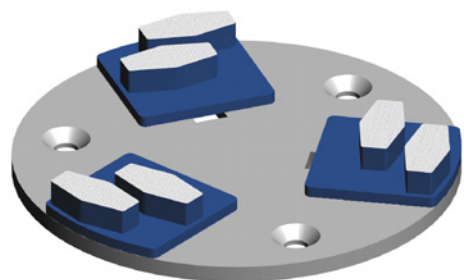

Figure 1-2 Scan-On plate with tools fitted.

1.4 Range of application



SC 450 is exclusively designed to process horizontal surfaces. SC 450 must not be used for other purposes than stated in this user guide. The manufacturer will not be liable for damage or injury resulting from incorrect usage of SC 450. Failure to follow the directions in this user guide will void the warranty.

Typical applications

- Removal of old coatings, carpets, putty from hard surfaces
- Removal of undulated concrete surfaces
- Preparation of the surface for coatings
- Polishing of the surface
- Removal of coating defects
- Removal of glue residues

SC 450 is recommended from small to medium sized work sites.

1.5 Scope of supply

The following parts are included with the standard SC 450 grinding machine:

- User Guide
- 5 mm hexagon socket key

Machines sold outside of Europe will be either equipped with a local standard connector for the power inlet or the mating connector will be included and fitted at the main power inlet.



Read “2.6 Electrical safety” before connecting any included connectors.

1.6 Overview

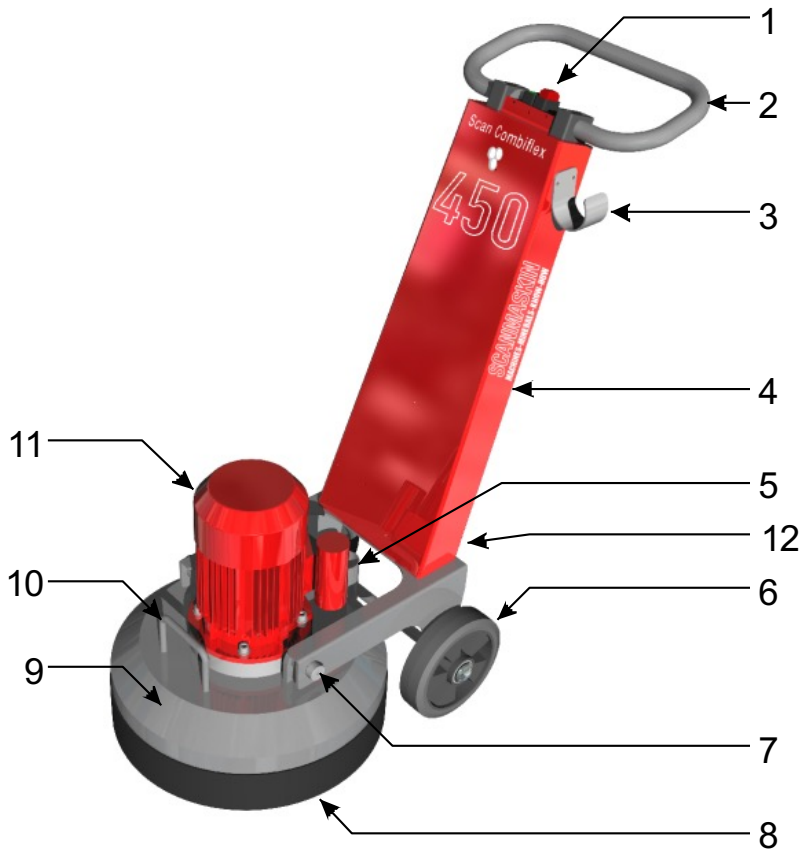

Figure 1-3 SC 450 overview

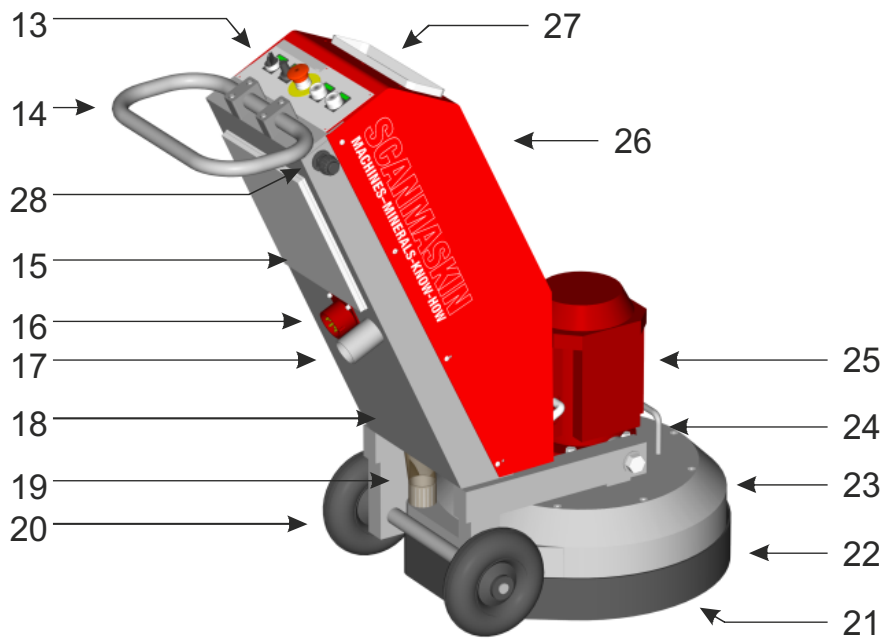

Figure 1-4 SC 450NS overview

Item	Description	Reference
1	Control device	<i>4.3 Control devic</i>
2	Handle	
3	Dust collector hose holder	
4	Frame	
5	Dust collector outlet	
6	Wheel	
7	Pin	
8	Dust cover	
9	Grinding head	<i>4.14 Changing tools</i>
10	Lifting handle	<i>3.3 Lifting</i>
11	Motor	<i>1.2 Mechanical specifications</i>
12	Connector motor - frame	
13	Control panel	
14	Handle	
15	Electrical cabinet	
16	Power inlet	
17	Dust collector connection	
18	Frame	
19	Dust hoses	
20	Wheels	
21	Gear barrel	
22	Dust cover	
23	Cover	
24	Lift handle	
25	Motor	
26	Cover	
27	Water tank	





Table 1-3 Machine parts overview

2 Safety Regulations



Read this entire chapter carefully! Failure to comply with safety regulations may result in serious injuries or damages.

2.1 Legend

	Notation regarding safety
	Notation regarding electrical safety
	Notation regarding safety during transport
	Tipping hazard
	See reference

2.2 Safety precautions



Any machine, if it is not used according the regulations, may be hazardous for operating, setting-up and service personnel. The operating authority is responsible for compliance with the safety regulations during operation and maintenance, and for the use of safety devices supplied with the machine, as well as the provision of appropriate additional safety devices!

Eye and ear protection must be worn at all times.

Never operate the machine when it's not in its upright position.

Make sure there is no debris in the work area.

Check the work area for screws or other hard objects in the concrete. Don't use the machine if there are any foreign objects stuck into the surface. Such objects must be removed prior to operation of machine.



Read “2.3 *Organizational measures*” and “2.5 *Safety regarding operation of machine*” thoroughly before operation!

2.3 Organizational measures



The user guide is to be kept near the location where the machine is being operated and must be within reach at all times.

In addition to this user guide general and legal regulations regarding accident prevention and environmental protection must be complied with as per local regulations.

Such duties may, for example, relate to the handling of hazardous substances, or to the provision and wearing of personal protection equipment, as well as compliance with traffic regulations.

The user guide must be supplemented by other instructions, including the duty to supervise and report incidents relating to particular working practices, for example work organization, work procedures and personnel safety.

Personnel entrusted with working with the machine must read the User Guide before starting work, in particular the “2 *Safety Regulations*” chapter. To read these instructions after work is commenced is too late. This particularly applies to incidental activities such as setting up the equipment, carrying out maintenance work or training staff to work with the machine.

From time to time the working practices of the operators are to be checked by a supervisor especially to the items regarding awareness of safety and hazards.

Operators must tie back long hair, and not wear loose clothing or jewelry including rings. There is a risk of injury through items getting caught, or being drawn into moving machinery.

Eye and ear protection must be worn at all times!

Use personnel protection equipment if necessary or required by local regulations! Take notice of all safety and hazard notices on the machine!

All safety and hazard notices at or on the machine must be kept complete and legible!

If safety-critical changes occur to the machine or its working method, the machine must be shut down immediately! The cause of the fault must be established, and rectified.

Changes, add-ons or conversion to the machine, which might impair safety, must not be made, without the manufacturer’s permission!

This applies in particular to the fitting and adjustment of safety devices.

Spare parts must comply with the technical requirements specified by the manufacturer. This is always guaranteed if original spare parts are used.

Intervals for recurring checks and inspections specified in this User Guide must be complied with!

To perform maintenance work correctly it is imperative to be equipped with the proper tools for the task in question.

Repairs may only be made by Scanmaskin Sweden AB certified service technicians.

Some grinding work may generate sparks under certain circumstances. Personnel working with the machine must therefore be aware of the risk of fire and how to handle a fire situation properly.

Do not use the machine in areas with highly flammable and/or explosive materials.

2.4 Personnel selection and qualification

Fundamental duties:

- Work with the machine may only be undertaken by trained personnel.
- Specify clearly the responsibilities of personnel for operation, setting up, servicing and maintenance work!
- Make sure that only authorized personnel operate or work with the machine!
- Define responsibilities of the machine operator, with regard to traffic safety regulations, and inform him not to take instructions from third parties who may not be complying with the local safety requirements.
- Personnel, who are being trained to operate equipment, may only use the machine under constant supervision of an experienced person!
- Work on electrical equipment may only be undertaken by a skilled electrician or by trained persons under the supervision of a skilled electrician, as well as in accordance with the local electrical engineering regulations.

2.5 Safety regarding operation of machine



Do not allow any method of working that impairs safety!

Recognized official procedures have to be used to ensure the machine is operated in safe and best conditions.

Only operate the machine when all safety devices and related safety equipment are present and operational!

Check the machine visually for any damage and defects at least once a day.

In the event of operational malfunctions the machine must be shut down immediately and secured!

Secure the work area around the machine in public areas providing a safety distance of at least 10 m (3.3 ft) from the machine.

Faults must be immediately rectified.

Carry out the switch on, and switch off operations in accordance with this user guide.

Before switching on the machine make sure that no-one can be endangered when the machine starts up.

Never operate the machine when not in its upright position.

Do not switch off or remove the exhaust and or the ventilation devices whilst the machine is running!

All persons in the proximity of the machine must wear ear and eye protection as well as safety shoes. In addition the machine operator must wear close-fitting protective clothing.

Only use extension cables that are sized and marked in accordance with the overall power consumption of the machine and the valid VDE guidelines.



See “2.6 Electrical safety” for further information.

Make sure there is no debris in the work area.

Check the work area for screws or other hard objects in the concrete. Don't use the machine if there are any foreign objects stuck into the surface. Such objects must be removed prior to operation of machine

2.6 Electrical safety



The power source must be equipped fuses according to the table in “1.1 Electrical specifications”. All cables used must be marked and rated according to the fuses used. Never connect the machine to a power source that does not provide protective earth!

Work on electrical equipment may only be undertaken by a skilled electrician or by trained persons under the supervision of a skilled electrician as well as in accordance with the local electrical engineering regulations.

Use only extension cables, that are used for extending the main cable, that are sized and marked in accordance with the overall power consumption of the machine and the valid VDE guidelines.

The electrical equipment for the plant must be inspected regularly. Defects such as loose connections or scorched cables must be rectified immediately. Call a skilled electrician or out customer services.

A second person must be in attendance whilst the electrical engineer is working on the equipment.

The work area must be secured against any third party entering the work area. Follow local electrical engineering regulations while working on the machine. Never leave a machine unattended. Use only tools that are insulated against electricity.

Only start work after you are familiar with the electrical engineering regulations that apply to the local area.

Only use voltage seekers that comply with the regulations when troubleshooting. From time to time check voltage seekers to ensure that they are operationally efficient.

2.6.1 Cables



Only use cables that are marked and rated according to the specifications in “1.1 Electrical specifications”. Don’t use excessive length of the cables. If a very long cable is needed we recommend that you use a cable rated for more current and connect it to a distribution central near the machine. Never lay the cable in a loop when operating the machine, this will cause the cable to heat up and may cause fire. See “Figure 2-1” for explanation.

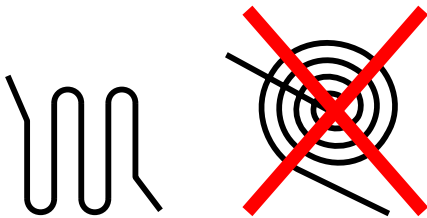

Figure 2-1 Recommended way to handle excessive cable length.

2.6.2 Using a generator



The generator must be equipped with protective earth and operated in accordance with the current EN-VDE directives (this applies to the protective earth conductor in particular) in order to ensure that all safety devices are functioning and eliminate possible damage to electrical components.

2.7 Definition of the “Safety off position”

The machine is in a safe condition where it cannot be any hazard.

How to set the machine in the Safety off position:

1. Switch off the machine
2. If a dust collector is used, switch it off
3. Wait for all drives to come to a complete stop
4. Disconnect the main power
5. Secure against unintended restart



Always disconnect the main power at the machine end to be able to prevent other persons from accidentally reconnect the main power while working on the machine.

2.8 Safety regarding maintenance

Set the machine into the Safety off position before beginning any work on the machine.



See “2.7 Definition of the “Safety off position””.

Never work on the machine while power is still connected!
All parts must have come to a complete stop before beginning any work!



When the machine is lying down on its back it might tilt to it's upwards position. Take extra care to prevent this from happening to ensure that no injuries or damages occur.



When the machine has been operated the segments, Scan-On plates and other parts on the gear barrel may be hot. Take extra care to prevent burn injuries.

Adjustment, servicing and inspection work on the period of time limits, specified in this User Guide as well as any information on the replacement or parts and equipment must be undertaken and/or complied with!

These activities may only be undertaken by qualified personnel.



The machine must not be connected to any power source while cleaning.



See “5.5 Cleaning the machine” for further information.

2.9 Safety regarding transport



Always remove the tools before transport. The tools may fall of or damage the surface the machine is transported along.

2.9.1 Manual transport



*When transporting the machine manually be observant about ramps and/or edges.
Follow local traffic regulations for the work site to prevent accidents. Failure to comply with these regulations may cause injuries or damages.*

2.9.2 Lifting



The machine must be secured according to local safety regulations before lifted.

No person is allowed beneath a lifted machine! The machine must be lifted according to the instructions in “3.3 Lifting”. Observe the machines point of balance before lifting! Failure to comply with these regulations may cause injuries or damages. Only use straps approved for the weight and circumstances!

2.9.3 Inside vehicles



Secure the machine according to local transport safety regulations before transporting the machine inside a vehicle.

3 Transportation

3.1 Safety precautions



Read “2.9 Safety regarding transport” before attempting to transport the machine.

3.2 Manual transportation

- Detach the tools according to the instructions in “4.14 Changing tools”.
- Tilt the machine backwards.
- Push the machine in desired direction.

3.3 Lifting



Before attempting to lift the machine, read “2.9.2 Lifting”

- Detach the tools according to the instructions in “4.14 Changing tools”.
- Fasten the straps used for lifting at the two handles as shown in “Lifting points SC 450 Figure 3-2”.
- Lift the machine.

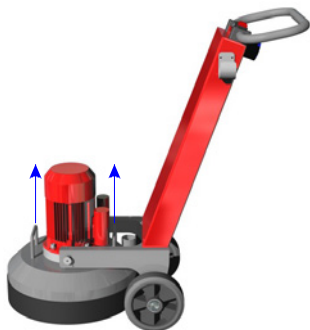

Figure 3-1 Lifting points SC 450

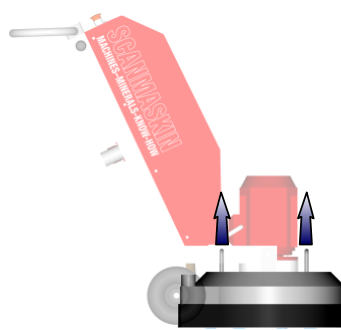

Figure 3-2 Lifting points SC 450 NS

3.4 Separation of machine

If the machine needs to be transported in a limited space it can be separated into two parts. On each side of the grinding head / motor assembly there is two pins, each fastened by a locking clip. To separate the machine, disconnect the motor cable; remove the locking clips and the pins. Take extra care to prevent the frame from falling backwards.

3.5 Inside vehicles

- Detach the tools according to the instruction in “4.14 Changing tools”.
- Secure the machine inside the vehicle.



Secure the machine according to local transport safety regulations before transporting the machine inside a vehicle. Failure to secure the machine may result in injuries or damages.

4 Operation

4.1 Precautions



Any machine, if it is not used according to the regulations, may be hazardous for operating, setting-up and service personnel. The operating authority is responsible for compliance with the safety regulations during operation and maintenance, and for the use of safety devices supplied with the machine, as well as the provision of appropriate additional safety devices!

Never operate the machine without proper tools.

Eye and ear protection must be worn at all times.

Never operate the machine when it's not in its upright position.

Make sure there is no debris in the work area.

Check the work area for screws or other hard objects in the concrete. Don't use the machine if there are any foreign objects stuck into the surface. Before operate the machine such objects must be removed.



Read "*2 Safety Regulations*" before operating the machine.

4.2 Machine functions

The gear barrel has got three grinding heads that rotates in the opposite direction of the gear barrel. Each grinding head is equipped with a Scan-on plate where each plate hold the tools used. See "*Figure 4-1*".



Figure 4-1 Illustrates the rotation of the grinding heads versus the gear barrel.



The machine is equipped with a thermal protection circuit that will shut down the machine in the event of high motor temperature. Wait at least 15 minutes before operating the machine again if this occurs.

4.3 Control device SC-450

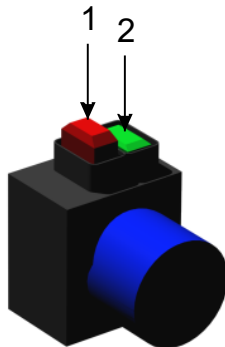

Figure 4-2 SC-450 control device

Item	Function	Description
1	Stop	Stops the SC-450
2	Start	Starts the SC-450

Table 4-1 Description of control device

4.4 Start up



See "4.1 Precautions" before starting the machine.

How to start the machine

- Make sure that the machine is equipped with the right "Scan on" tools.
- Make sure that the main power and hoses for the dust collector are connected to the machine.
- Turn on the dust collector if used.
- Push the handle downwards to lift the gear barrel about 10 cm (4") from the ground.
- Press the start button (2) on the control device.
- Lower the gear barrel down to the floor.
- Never let go of the handle during operation.

4.5 Stop

How to stop the machine

- Press the stop button (1)
- Wait until the machine comes to a complete stop before letting go of the handle
- If a dust collector is used, turn off

4.6 Control panel SC 450NS



Figure 4-3 Control panel of SC 450NS.

No.	Text	Description	Part number
1	L/R	Selects rotation direction	596001
2	SPEED	Selects speed ⁵	596009
3	EMERGENCY STOP	Emergency stop	596003
4	STOP	Stops the machine	596007
5	START	Starts the machine	596006

Table 4-2 Description of the control panel.

4.6.1 Water tank SC 450NS



To increase the flow of the water turn the knob counter clockwise. The knob will move outwards.

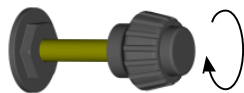

To decrease the flow of the water, turn the knob clockwise. The knob will move inwards.

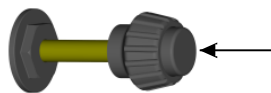

To quickly stop the water flow, push the button on the knob. This releases the knob and a spring will pull it inwards.



Secure the knob by tighten it slightly to ensure that no water will flow.

⁵ The range of the speed selection knob is described in "1.2 Mechanical specifications".

To empty the water tank before lying down transport, increase the water flow to a maximum and let the water pour out. Make sure the tank is empty before lying down transport.

Empty the tank before long time storage.

4.7 Start up the SC 450NS



See "4.1 Precautions" before starting the machine.

How to start the machine

- Make sure that the power plug and hoses for dust collector and water (if water supply is used) are connected to the machine.
- Turn on the dust collector if used.
- Push the handle downwards to lift the gear barrel about 10 cm (4") from the ground.
- Make sure that the "EMERGENCY STOP" is in its upper position.
- Press the "START" button on the control panel.
- Lower the gear barrel down to the floor.

4.8 Emergency stop / Reset SC 450NS

Use the Emergency Stop button to quickly stop the machine to prevent an accident or injuries.

Reset procedure:

- Turn the Emergency Stop button clockwise to release it
- Press the Stop button

The machine is now ready to be started again.

4.9 Stop the SC 450 NS

How to stop the SC 450NS machine

- Press the "STOP" button.
- Wait for the machine to come to a complete stop before letting go of the handle.
- Turn off the dust collector if used.

4.10 Grinding speed SC 450NS

Use the "SPEED" dial to adjust the rotation speed of the grinding discs between the intervals described in chapter 1.

4.11 Rotation direction SC-450 NS

Use the "L/R" switch to change direction of the grinding discs. The machine will first do a soft stop then a soft start.

4.12 Safety off position

When working on the machine, maintenance or tool change, the machine must be set to the “Safety off position”. See “2.7 Definition of the “Safety off position”” for further information.

4.13 Grinding

Refer to “Grinding guide” for instructions and information about grinding.

4.14 Changing tools



Before changing tools, read “2.8 Safety regarding maintenance”.

This illustration shows how to change the tools.

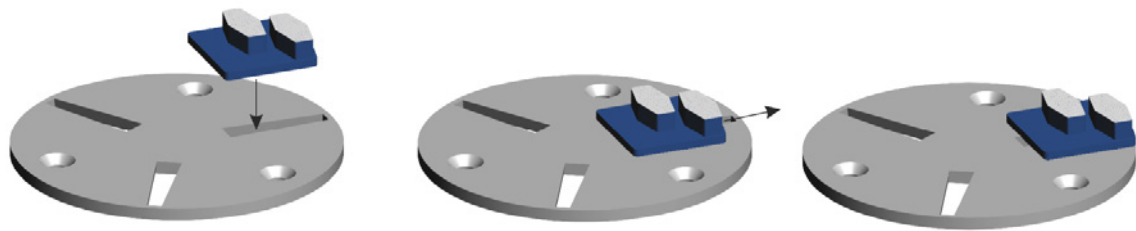

Figure 4-4 How to fit the diamond tools on the Scan-On plate

- Insert the segment at the widest part of the slot
- Push the segment outwards
- The segment is now fit on the Scan-On plate

To make sure that the tool is secured, use a small plastic hammer and slightly hit the tool outwards. In reverse this technique can be used to loosen tools that are stuck.

5 Maintenance

5.1 Precautions

Set the machine into the Safety off position before beginning any work on the machine.



See “2.7 Definition of the “Safety off position””.



Read “2.6 Electrical safety” before beginning any maintenance work.

Never work on the machine while power is still connected!

All parts must have come to a complete stop before beginning any work!



When the machine is lying down on its back it might tilt to it’s upwards position. Take extra care to prevent this from happening to ensure that no injuries or damages occur.



When the machine has been operated the segments, Scan-On plates and other parts on the gear barrel may be hot. Take extra care to prevent burn injuries.

Adjustment, maintenance and inspection work must be undertaken by qualified personnel.



The machine must not be connected to any power source while cleaning.

5.2 Daily inspection prior to operation

Inspect the following items prior to operation

- Inspect the wheels for damage.
- Inspect the grinding discs and hubs.
- Inspect the grinding head, dirt between the Scan-On plate and the grinding hub may lower the flexibility of the grinding head.
- If any screws appear loose, tighten them.
- Look over the machine for any other damage.

5.3 Maintenance and inspection list

Daily	<ul style="list-style-type: none"> ▪ Inspect the wheels ▪ Inspect the grinding heads ▪ Look for any other damage
12 hours after service	<ul style="list-style-type: none"> ▪ Tighten all screws

5.4 Grinding disc replacement / assembly

Follow these steps to replace the Scan-On plate

- Make sure the machine is in its “Safety off position”
- Tilt the machine backwards and secure it.
- Remove any tools used according to”4.14 Changing tools”.
- Loosen the three screws holding the Scan-On plate.
- Replace the Scan-On plate.
- It’s recommended that new screws are used to fasten the replacement Scan-On plate.
- It’s also recommended that copper paste is used on the surface of the screw hole at the Scan-On plate.
- Tighten all screws by hand and make sure that they are secured.

5.5 Cleaning the machine



Before starting to clean the machine, make sure it is in its”Safety off position”



The power must not be connected while cleaning the machine.

Do not use highly pressurized water to clean the machine.
Water and soap is recommended.

5.6 Trouble shooting

5.6.1 Common faults

Symptom	Cause	Correction	A ⁶
The machine won't start	<ul style="list-style-type: none"> ▪ There is a power failure from the power supply 	<ul style="list-style-type: none"> ▪ Inspect the fuses in the worksites fuse box ▪ Inspect cables ▪ Measure that all three phases are present and at full voltage near the machine 	O E E
The machine only operates while the start button is depressed	<ul style="list-style-type: none"> ▪ The motor is overheated 	<ul style="list-style-type: none"> ▪ Wait until the motor is cool again 	O
	<ul style="list-style-type: none"> ▪ The control device is damaged 	<ul style="list-style-type: none"> ▪ Replace the control device 	S
The machine is weak and might stop when on the ground.	<ul style="list-style-type: none"> ▪ There is a voltage drop at the power supply 	<ul style="list-style-type: none"> ▪ Inspect the fuses in the worksites fuse box ▪ Inspect cables ▪ Measure that the main voltage is present and at full voltage at the cable end near the machine. 	O E E
		<ul style="list-style-type: none"> ▪ Make sure that the cable is not too long. If the cable should be too long, use a cable with higher rating to a distribution box nearer the machine. 	O
The machine vibrates a lot	<ul style="list-style-type: none"> ▪ The grinding speed is to high 	<ul style="list-style-type: none"> ▪ Lower the speed 	O
	<ul style="list-style-type: none"> ▪ The tools are damaged 	<ul style="list-style-type: none"> ▪ Inspect the tools ▪ Change the tools if needed 	O O

5.6.2 Error codes SC-450 NS

Code	Description	Cause	Correction	A ⁷
A2001	Over current	<ul style="list-style-type: none"> One of the three phases is missing from the power supply There is a voltage drop at the power supply 	<ul style="list-style-type: none"> Inspect the fuses in the worksites fuse box Inspect cables Measure that all three phases are present and at full voltage at the cable end near the machine Make sure that the cable is not too long. If the cable should be too long, use a cable with higher rating to a distribution box nearer the machine 	O O E E
		<ul style="list-style-type: none"> The environmental temperature is too high. When the temperature is above 40°C (104°F) the inverter will decrease its maximum output current 	<ul style="list-style-type: none"> Inspect the ventilation fans Inspect the filters to the fans 	O O
A2002	Over voltage	<ul style="list-style-type: none"> The power supply has got voltage transients 	<ul style="list-style-type: none"> Inspect the power source 	E
A2003	Under voltage	<ul style="list-style-type: none"> One of the three phases is missing from the power supply There is a voltage drop at the power supply 	See A2001	
A2006	Speed reference error	<ul style="list-style-type: none"> The potentiometer on the control panel is damaged 	<ul style="list-style-type: none"> Inspect the potentiometer Replace if necessary 	S S
A2009	Over temperature	<ul style="list-style-type: none"> The internal temperature in the inverter is above 120°C (248°F). This could be caused by faulty ventilation in the electrical cabinet. 	<ul style="list-style-type: none"> Inspect the ventilation fans Inspect the filters to the fans Contact Scanmaskin Sweden AB 	O O
A5001	Internal error	Contact Scanmaskin Sweden AB		
F0001	Over current	See A2001		
F0002	Over voltage	See A2002		
F0003	Over temperature	<ul style="list-style-type: none"> The internal temperature in the inverter is above 135°C (275°F). This could be caused by faulty ventilation in the electrical cabinet. 	See A2009	
F0004	Short circuit in motor	<ul style="list-style-type: none"> The cable to the motor has been damaged The motor has been damaged 	<ul style="list-style-type: none"> Inspect the motor cable Inspect the motor connection Contact Scanmaskin Sweden AB 	E E
F0006	Under voltage	See A2003		
F0007	Speed reference error	See A2006		
F0016	Protective earth failure	<ul style="list-style-type: none"> The cable to the motor has been damaged The motor has been damaged Water have entered the motor 	<ul style="list-style-type: none"> Inspect the motor cable Inspect the motor connection Contact Scanmaskin Sweden AB 	E E
F0018	Internal error	Contact Scanmaskin Sweden AB		
F0021				
F0022	Power supply phase fault	See A2003		
F0034	Motor phase fault	<ul style="list-style-type: none"> One of the three phases to the motor is missing. This could be due to damage to the motor cable or to the motor. 	<ul style="list-style-type: none"> Inspect the motor cable Inspect the motor connection Contact Scanmaskin Sweden AB 	E E

Table 0-1 Error codes

Alarm codes starts with “A” and fault codes starts with “F”. The machine will be operational if an alarm code is present but not when an fault code is present.

The following table describes the access for the task.

Abbreviation	Person
O	Machine Operator
E	Electrician
S	Scanmaskin certified service technician

Table 0-2 Access rights for different persons

⁷ See access table ”Table 0-2”

6 Spare parts

6.1 Gear barrel

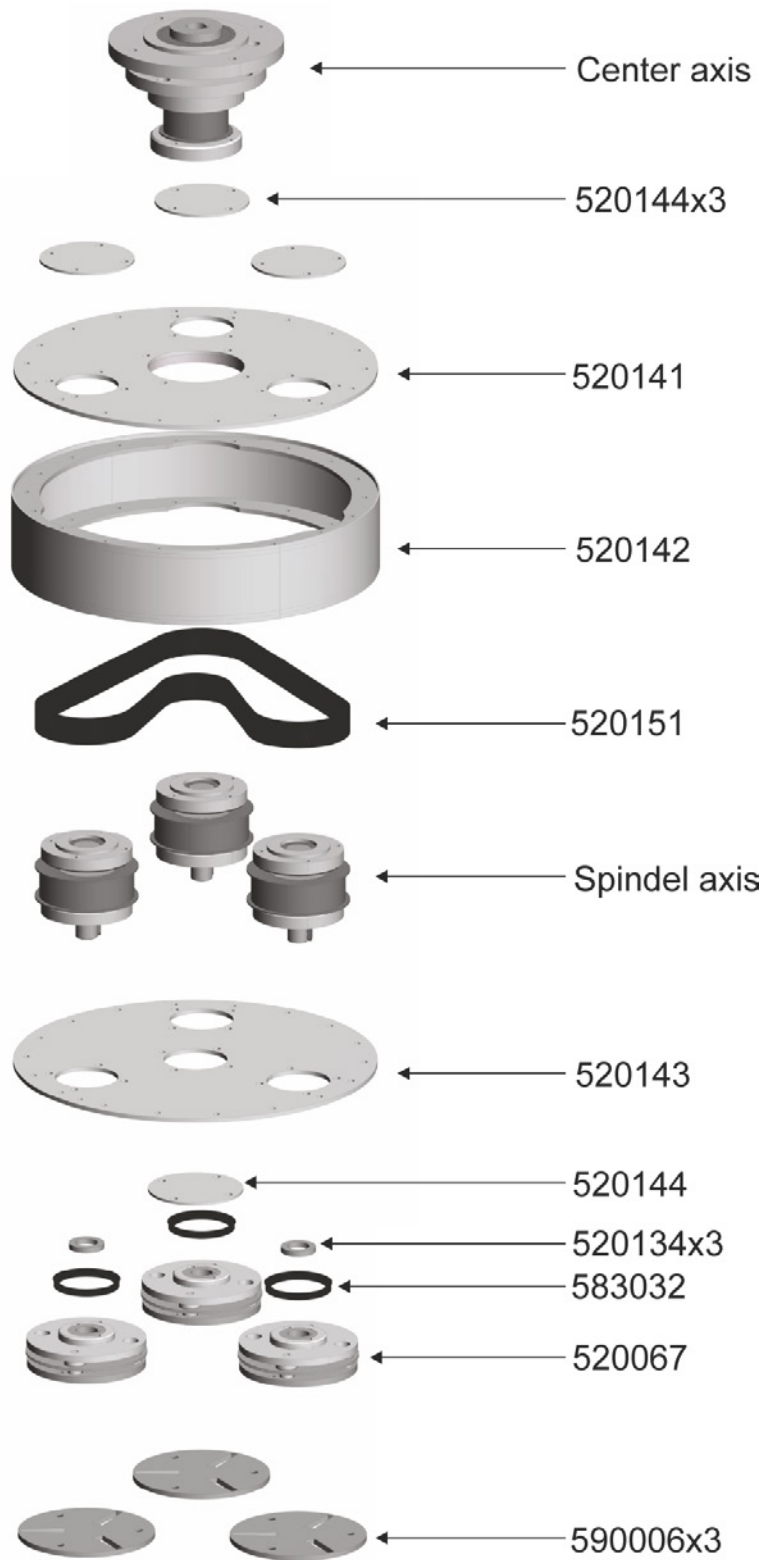

Gear barrel SC - 450	
520067	FLEX TOOL HOLDER SC-450/500/SM-18
520134	SPACER for AXLE, FLEX TOOL HOLDER, 18/450/500/650/700/800
520141	UPPER PLATE
520142	GEAR HOUSING
520143	LOWER PLATE
520144	COVER PLATE FOR BEARING BOX
520151	DRIVE BELT SC-450
583032	V-RING 65 FLEX TOOL HOLDER
590006	SCAN-ON FASTENING DISCS, SC-450/500/SM-18

6.2 Center axis

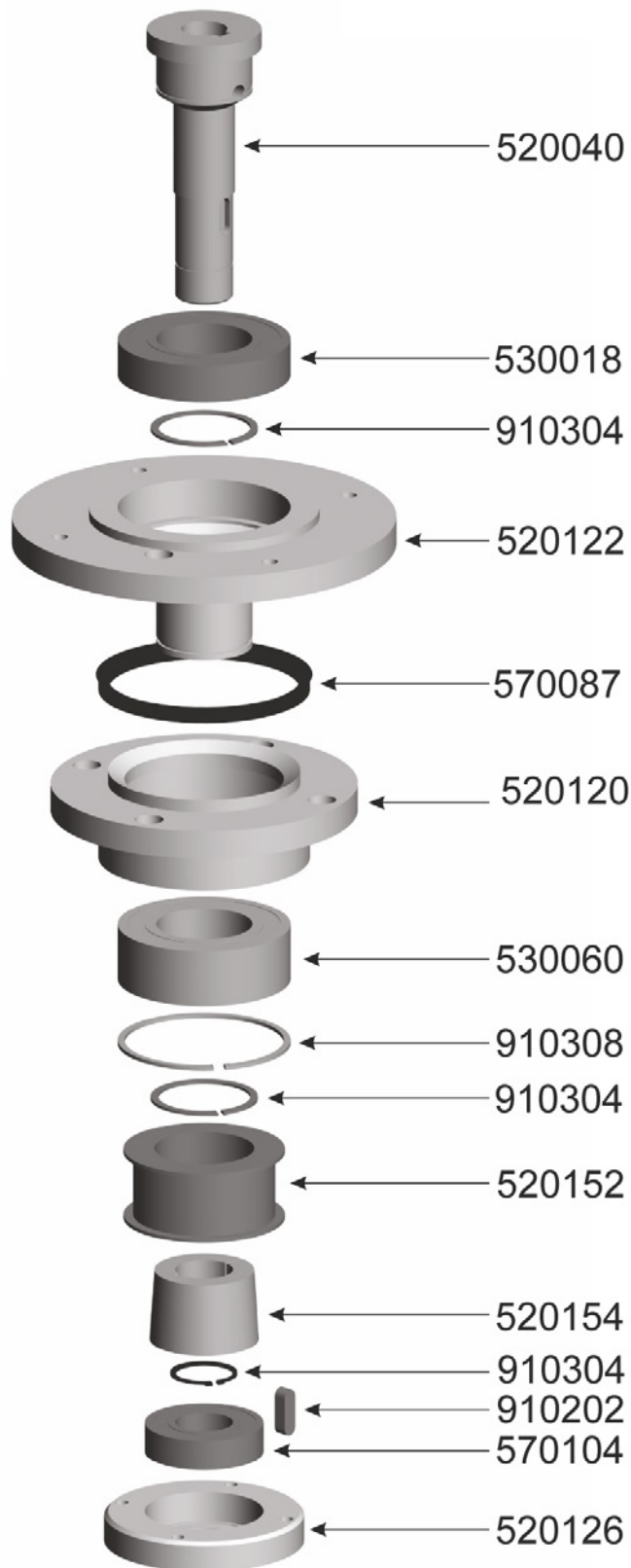

Center axis SC - 450	
520040	CENTER AXEL
520120	CENTRAL BEARING BOX
520122	UPPER ROTATING BEARING BOX
520126	BEARING BOX SM-18/450/500/650/700/800
520152	GEARWHEEL CENTRE (BL30-8M-30) SC-450
520154	TAPER LOCK FOR CENTRE GEARWHEEL (1615-30) SC-450
530018	BEARING 6210-RS1, SC-330/450/500/ SM-18
530060	BEARING 3210 2RS1 SC-450/500/SM-18
570087	V-RING V-100A SM-18/SC-450/500
570104	BEARING 6206 SM-18/SC-450/500/650/700/800/1000
910202	PARALLEL KEY 8x7x20
910304	CIRCLIP SGA 30
910304	CIRCLIP SGA 30
910304	CIRCLIP SGA 30
910308	CIRCLIP SGH 90

6.3 Spindel axis

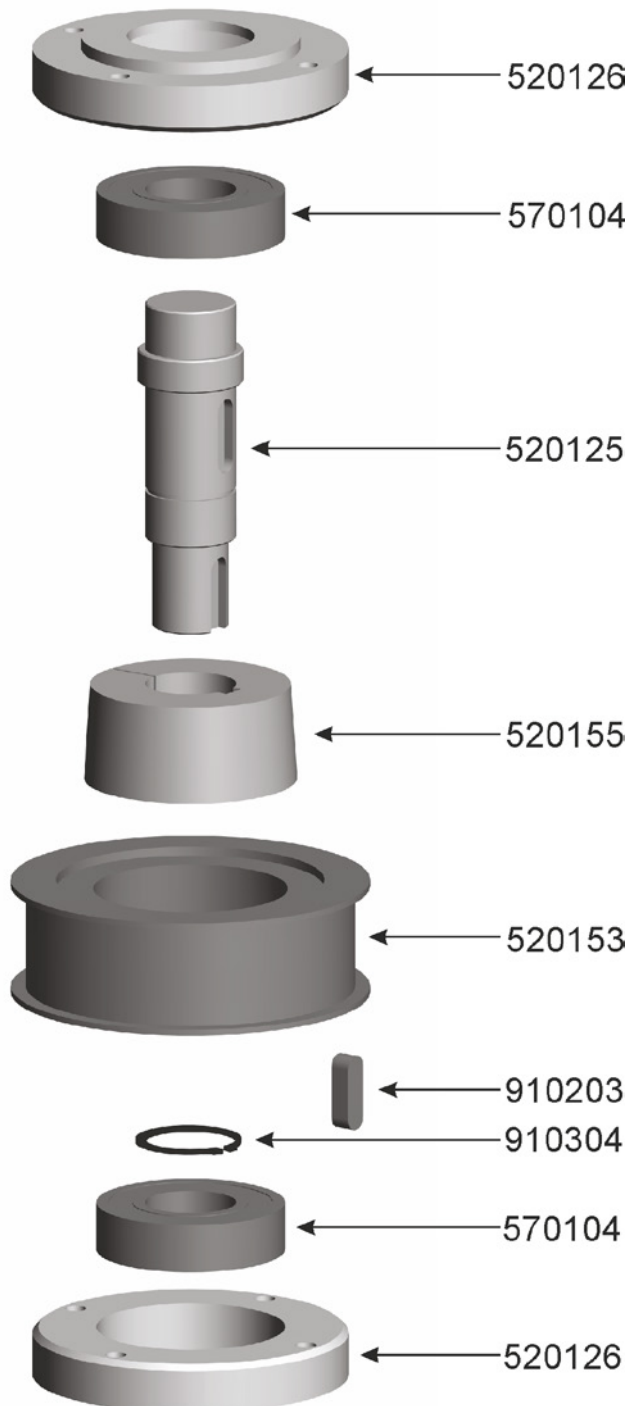

Spindel axis SC - 450	
520125	GRINDING AXLE SC-450/SM-18
520126	BEARING BOX SM-18/450/500/650/700/800
520126	BEARING BOX SM-18/450/500/650/700/800
520153	GEARWHEEL GRINDING AXLE SC-450
570104	BEARING 6206 SM-18/SC-450/500/650/700/800/1000
570104	BEARING 6206 SM-18/SC-450/500/650/700/800/1000
910203	PARALLEL KEY 8x7x25

6.4 Grinding head

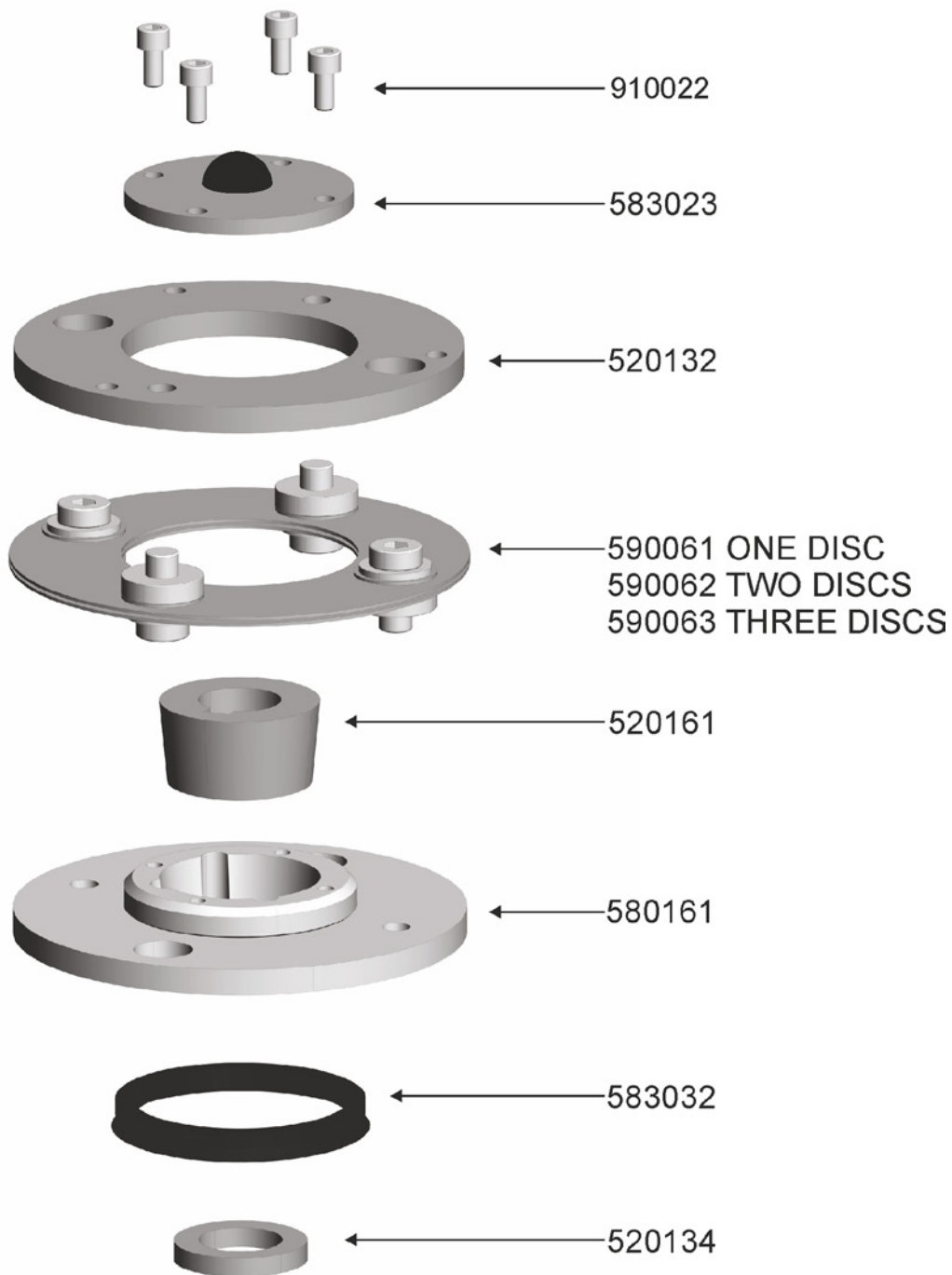

Grinding head SC - 450	
520132	LOWER FASTENING PLATE, FLEX TOOL HOLDER SC-450/500/SM-18
520134	SPACER for AXLE, FLEX TOOL HOLDER, 18/450/500/650/700/800
520161	TAPER LOCK BUSHING 25mm FLEX TOOL HOLDER, 18/450/500/800/
580161	CENTRAL HUB FLEX TOOL HOLDER
583023	COVER FOR CENTRAL HUB, FLEX TOOL HOLDER
583032	V-RING 65 FLEX TOOL HOLDER
590061	EXCHANGE KIT FLEX TOOL HOLDER (1 DISC)
590062	EXCHANGE KIT FLEX TOOL HOLDER (2 DISC)
590063	EXCHANGE KIT FLEX TOOL HOLDER (3 DISC)
910022	SCREW ALLEN KEY M6 x 12

7 Warranty

This product from Scanmaskin Sweden AB comes with a twelve month warranty. If the product does not function satisfactorily during this period, Scanmaskin will return the product to full working order for normal use which the product is intended for – with no charge for labor or spare parts, according to the following conditions:

1. The warranty only applies to persons that have legal right to the equipment during the warranty period.
2. The manufacturer's undertaking is limited to the repair of defective parts or the replacement of these according to the manufacturer's assessment. Costs and risks for transport as well as dismantling and reinstallation of the product / products and other direct or indirect costs, associated with the repair in question, are not covered by this warranty.
3. Periodic inspections, adjustments, maintenance work and changes are not covered by the warranty.
4. Scanmaskin is not liable for any damages to grinding discs or other similar equipment.
5. The warranty only applies to material and design deficiencies and does not apply in the following cases:
 - a. Damage caused through accidents, carelessness, changes, use of spare parts or grinding tools that are not original components, or incorrect use and installation.
 - b. Damage caused by lightning, water, fire, vandalism, incorrect mains voltage, incorrect ventilation or other causes that lie outside of the manufacturer's control.
6. Scanmaskin reserves the right to modify the design – or make improvements without obligation to change previously manufactured products.
7. All warranty repairs must be carried out by Scanmaskin or by a Scanmaskin authorized repair workshop. Costs for repairs, carried out by an unauthorized workshop, will not be reimbursed by Scanmaskin. If such repairs damage this product these are not covered by the warranty agreement.

8 EU Declaration

Declaration of CE conformity

Manufacturer Scanmaskin Sweden AB
Address Heljesvägen 10
427 36 Lindome / Gothenburg
Sweden

Product Grinding machine

Product name Scan Combiflex 450

Serial number _____

The product conforms with the following EU guidelines

Machine directives 2006/42/EG
EMC 2004/108/EG
LVD 2006/95/EG
Harmonized standards EN ISO 13850
EN ISO 12100-1/-2
EN ISO 60204-1

Location of issue Lindome / Gothenburg / Sweden

Authorized representative Claes-Göran Bergstrand
Managing Director

Scanmaskin Sweden AB
2010-01-01

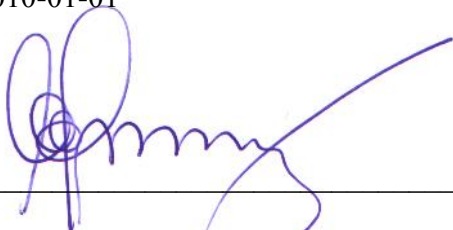

Claes-Göran Bergstrand
Managing Director

9 Alphabetical reference

C

Contact information	74
Control device	56
Control panel.....	57

D

Dimensions	
SC-450.....	41

E

Error codes	62
EU Declaration.....	72

F

Fuse	
External.....	40

I

Inspection	
daily	60
Maintenance and inspection list	60

M

Maintenance	
Access	62
Error codes	See Error codes

O

Overview	
SC-450.....	44

S

Separation of machine	53
Snap-On-plate	
replacing	61
Specifications	
Electrical	40
Start.....	56
Stop	56

T

Tools	
Available tools	42
changing	59
Transport.....	53
lifting.....	53
manual.....	53
Trouble shooting	
common faults.....	61

W

Warranty	71
Water	
tank.....	57

10 Contact information

Sweden (Head Office)

Heljesvägen 10
Box 187
SE-437 22 Lindome

Phone: +46 (0) 31 99 49 70
Fax: +46 (0) 31 99 48 70
E-mail: info@scanmaskin.se
Website: www.scanmaskin.se

Denmark

Torvegade 22
DK-7330 Brande

Phone: +45 97 18 00 58
Fax: +45 97 18 45 58
E-mail: info@scanmineral.dk
Website: www.scanmaskin.se

Norway

Postboks 6, Furuset
N-1001 Oslo
Tomtveien 12
NO-2015 Leisund

Phone: +47 63 87 60 00
Fax: +47 63 87 60 01
E-mail: info@scanmaskin.no
Website: www.scanmaskin.no

Finland

Raudoittajantie 3 A
FIN-06450 Porvoo / Borgå

Phone: +358 10 292 4700
E-mail: info@scanmaskin.fi
Website: www.scanmaskin.fi

USA

1407 132nd Avenue Northeast, Suite 8
Bellevue, Washington, 98005

Phone: +1 425 209 0147
E-mail: info@scanmaskin.com
Website: www.scanmaskin.com

SCANMASKIN

MACHINES—MINERALS—KNOW-HOW

SCANMASKIN SWEDEN AB

Huvudkontor / Head office

Box 187

SE-437 22 Lindome

Phone: +46 (0)31- 99 49 70

Fax: +46 (0)31- 99 48 70

Email: info@scanmaskin.com

Besöksadress / Visiting address

Heljesvägen 10

SE-437 36 Lindome

www.scanmaskin.com

Kære kunde!

Tak fordi du har valgt Scanmaskin som leverandør. Vi ønsker dig held og lykke med din nye Scan Combiflex 450 og håber, at den svarer til dine forventninger.

Scanmaskin Sverige AB



Claes-Göran Bergstrand
Administrerende direktør

Adresse:

Scanmaskin Sverige AB
Box 187
SE-437 22 Lindome / Göteborg
Sverige

Telefon: +46 (0) 31 99 49 70

Fax: +46 (0) 31 99 48 70

www.scanmaskin.se

<http://www.scanmaskin.com>

Denne brugermanual vedrører kun gulvslibemaskinen “**Scan Combiflex 450**” og “**Scan Combiflex 450NS**” herefter benævnt som “**SC-450**”. Ved specifik information og instruktioner til Scan Combiflex 450NS benævnes den maskine ”**SC-450NS**”. SC-450 må kun bruges til slibning af horisontale flader, som er godkendt af Scanmaskin Sverige AB.

Hvis SC-450 bruges til andre formål eller håndteres på en anden måde end beskrevet i denne brugermanual, så fraskriver Scanmaskin Sverige AB sig alt ansvar.

Bemærk kapitel ”2 Sikkerhedsforskrifter”. Læs brugermanualen inden gulvslibemaskinen SC-450 tages i brug. Reservedele og slibeværktøj som bruges til SC-450 skal være godkendt af Scanmaskin Sverige AB.

Indholdsfortegnelse

1	Specifikationer	2
1.1	Elektriske specifikationer	2
1.2	Mekaniske specifikationer	3
1.3	Værktøj	4
1.4	Anvendelsesområde	5
1.5	Indhold ved levering	5
1.6	Oversigt	6
2	Sikkerhedsforskrifter	8
2.1	Symbolforklaring	8
2.2	Sikkerhedsforanstaltninger	8
2.3	Organisationsforanstaltninger	9
2.4	Personale og kvalifikationer	10
2.5	Sikkerhed ved brug af maskinen	10
2.6	El-sikkerhed	11
2.6.1	Ledninger	13
2.6.2	Brug af generator	13
2.7	Definition af ”Slukket og sikker stilling”	13
2.8	Sikkerhed som vedrører service	14
2.9	Sikkerhed under transport	14
2.9.1	Manuel transport	14
2.9.2	Løftning	14
2.9.3	Inde i et køretøj	14
3	Transport	15
3.1	Sikkerhedsforanstaltninger	15
3.2	Manuel transport	15
3.3	Løftning	15
3.4	Deling af maskine	15
3.5	Inde i et køretøj	15
4	Håndtering	16
4.1	Forsigtighedsforanstaltninger	16
4.2	Maskinens funktion	16
4.3	Manøvregrab SC-450 Standard	17
4.4	Opstart	17
4.5	Stop	17
4.6	Kontrolpanel SC-450NS	18
4.6.1	Vandtank SC-450NS	19
4.7	Opstart SC-450NS	19
4.8	Nødstop / tilbagestilling SC-450NS	20
4.9	Stop SC-450 NS	20
4.10	Hastighedsregulering SC-450NS	20
4.11	Rotationsretning SC-450NS	20
4.12	Slukket og sikker stilling	20
4.13	Slibning	20
4.14	Værktøjsskift	21
5	Service	22
5.1	Sikkerhedsforanstaltninger	22
5.2	Daglig inspektion før brug	22
5.3	Service- og inspektionsskema	22

5.4	Skift af Scan-On-fæsteskive	23
5.5	Rengøring af maskinen	23
5.6	Fejlsøgning	23
5.6.1	Almindelige problemer	23
5.6.2	Alarm- og fejlkoder SC-450NS.....	24
6	Reservedele	25
6.1	Maskinhus.....	25
6.2	Centeraksel	26
6.3	Slibeaksel.....	27
6.4	Slibehoved	28
7	Garanti	28
8	EF-Deklaration	30
9	Alfabetisk register	31
10	Kontakt	32

1

1 Specifikationer

1.1 Elektriske specifikationer

For at finde de specifikationer som vedrører din maskine, ska du kontrollere informationskiltet som sidder fast på maskinens forside. (Se ”Figur 1-3” for mere information)



Tilslut aldrig SC-450 til andre forsyningsspændinger end beskrevet i denne specifikation.



Kraftkilden skal være afsikret ifølge ”Ekstern sikring” i denne specifikation. Ledningerne som bruges skal være mærket og godkendt til den brugte sikring. Det kan medføre brand eller skader, hvis der bruges forkerte sikringer.

Forsyningsalternativer	230 V 1~ ¹	230 V 1~ ²	110 V 1~
Effekt	1,5 kW (2 hk)	2.2 kW (3 hk)	1,5 kW (2 hk)
Strøm	8.7 A	12 A	18.5 A
Spænding	200 – 240 V 1~	200 – 240 V 1~	100 – 130 V 1~
Frekvens	50 Hz +/- 5%	50 Hz +/- 5%	60 Hz +/- 5%
Ekstern sikring ³	10 A	10 A	20 A
El-indtag ⁴	CEE 7/7 – 250V 16A + PE	CEE 7/7 – 250V 16A + PE	NEMA 5-20 – 125V 20A + PE

Tabel 0-1 Elektriske specifikationer

Alle modeller er CE-mærket.



Hvis der bruges en generator, læs ”2.6.2 Brug af generator”



¹ Standard

² 2,2kW motor / NS model

³ Vedrører sikringen i kraftkilden, f.eks. strømtavlen.

⁴ Dette er standardindtaget som medfølger. Maskiner som er solgt uden for EU sendes enten med et lokalt indtag eller en adapter.

1.2 Mekaniske specifikationer

Model	SC-450 Standard	SC-450 NS
Realiseringsdiameter	450 mm	450 mm
Slibeskivernes diameter	150 mm	150 mm
Slibeskivernes omdrejningstal	950 omdrejninger/min	300-1000 omdrejninger/min
Vægt	90 kg	100 kg
Slibehoved	Frigående 	Frigående 

Tabel 0-2 Mekaniske specifikationer

Dimensioner på SC-450

Bredde	460 mm
Højde	1030 mm
Dybde	810 mm

Dimensioner på fragtkasse

Bredde	610 mm
Højde	1430 mm
Dybde	810 mm

Omgivelsestemperatur under drift	-20°C til +40°C
Omgivelsestemperatur under opbevaring	-20°C til +70°C



Figur 1-1 Standard SC-45



Figur 1-2 SC-450NS

1.3 Værktøj



Maskinen skal udstyres med værktøj som er godkendt af Scanmaskin Sverige AB inden den tages i brug.



Se "Slibeguiden" for information om tilgængelige værktøj og "4.14 Værktøjsskift" for information om hvordan man skifter værktøj.

Værktøjet sidder fast med Scan-On-systemet for nemt værktøjsskift.

Tilgængeligt værktøj

- Riveværktøj
- Diamantværktøj
- Sandpapir

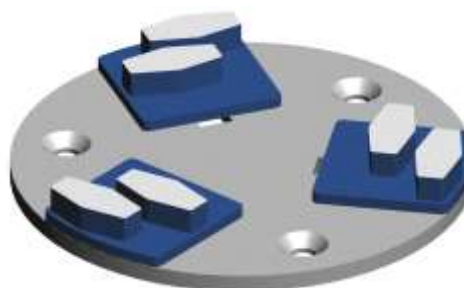

Figur 0-2 Scan-On-fæsteskive med værktøj.

1.4 Anvendelsesområde



SC-450 er designet til horisontale flader. SC-450 må ikke bruges til andre formål end de, som er beskrevet i denne brugermanual. Producenten kan ikke holdes ansvarlig for materielle eller personskader, som er forårsaget af forkert brug af SC-450. Hvis brugermanualen ikke følges, erklæres garantien ugyldig.

Typiske anvendelsesområder

- Fjernelse af gamle belægninger, tæpper og spartel fra hårde flader
- Udglatning af betonflader
- Forberedelse til belægning på flader
- Polering af flader
- Fjernelse af belægningsdefekter
- Fjernelse af limrester

SC-450 anbefales til små til mellemstore arbejdsflader.

1.5 Indhold ved levering

Følgende er inkluderet med SC-450 ved levering.

- Brugermanual
- 5 mm unbrakonøgle

Maskiner som sælges uden for Europa vil enten være udstyret med et el-indtag som følger den lokale standard eller en passende kontaktfordobindelse som sidder i el-indtaget.



Læs "2.6 El-sikkerhed" inden medfølgende tilslutninger tilkobles.

1.6 *Oversigt*

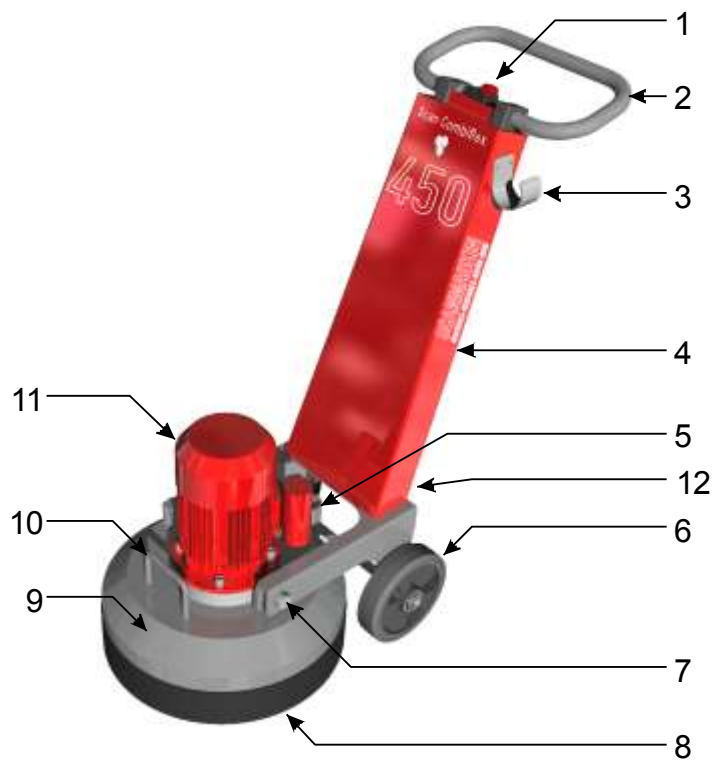

Figur 1-3 SC-450 oversigt

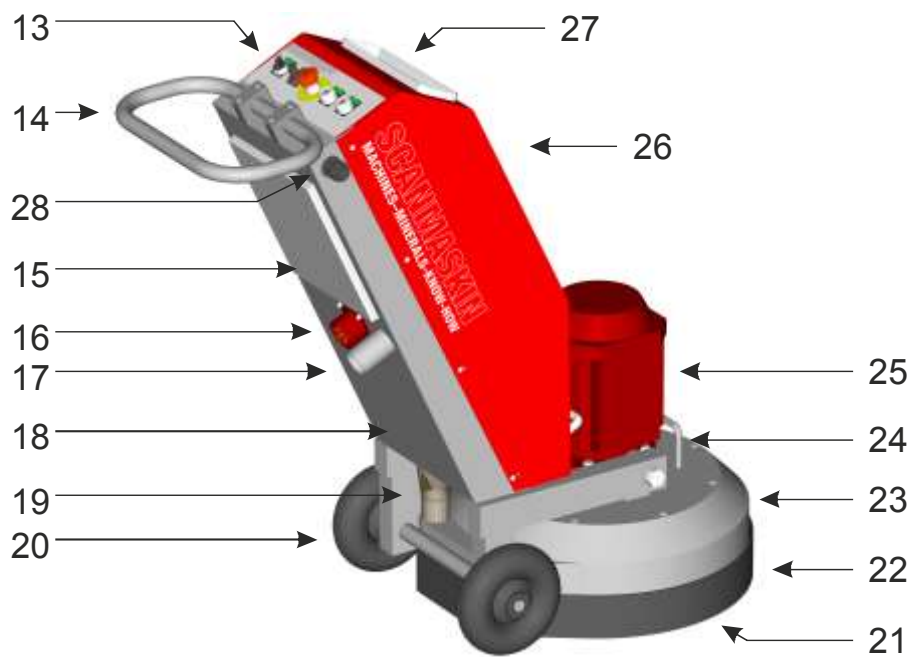

Figur 1-4 SC-450NS

Nummer	Beskrivelse	Reference
1	Manøvregrab	4.3 Manøvregrab
2	Håndtag	
3	Holder til støvsugerslange	
4	Vogn	
5	Støvsugerudtag	
6	Hjul	
7	Stift	
8	Støvbeskyttelse	
9	Slibehoved	4.14 Værktøjsskift
10	Løftehåndtag	3.3 Løftning
11	Motor	
12	Skillekontakt motor – vogn	
13	Kontrolpanel	
14	Håndtag	
15	El-skab	
16	El-indtag	
17	Støvsugertilslutning	
18	Chassis	
19	Nedre slange	
20	Hjul	
21	Maskinhus	
22	Støvbeskyttelse	
23	Beskyttelsesskærm	
24	Løftehåndtag	
25	Motor	
26	Skærm	
27	Vandtank	

Tabel 0-3 Oversigt over maskindele

2 Sikkerhedsforskrifter



Læs hele dette kapitel nøje igennem! Hvis sikkerhedsforskrifterne ikke læses, kan det medføre personskader eller materielle skader.

2.1 Symbolforklaring

	Sikkerhedsnotat
	El-sikkerhedsnotat
	Transportsikkerhedsnotat
	Tipningsrisiko
	Reference til mere information

2.2 Sikkerhedsforanstaltninger



Alle maskiner som ikke bruges ifølge sikkerhedsforskrifterne kan være farlige at bruge, indstille eller udføre service på. Arbejdslederen er ansvarlig for at sikkerhedsforskrifterne følges, både under brug og service af maskinen samt at sikkerhedsfunktioner som følger med maskinen bruges. Arbejdslederen er også ansvarlig for at stille passende øvrigt sikkerhedsudstyr til rådighed!

Beskyttelsesbriller og høreværn skal bæres hele tiden.

Maskinen må kun startes i oprejst stilling.

Sørg for at der ikke ligger affald på arbejdsfladen.

Undersøg arbejdsfladen for skruer eller andre hårde genstande som sidder i fladen. Brug ikke maskinen hvis der sidder fremmede genstande fast i fladen. Disse genstande skal fjernes inden maskinen bruges.



Læs "2.3 Organisationsforanstaltninger" og "2.5 Sikkerhed ved brug af maskinen" nøje igennem inden maskinen tages i brug!

2.3 Organisationsforanstaltninger



Brugermanualen skal opbevares i nærheden af det sted hvor maskinen bruges og skal hele tiden være inden for rækkevidde.

Udover denne brugermanual så skal almene og lovbestemte foranstaltninger angående ulykkesforhindring og miljøbeskyttelse følges såvel som de lokale forskrifter.

Sådanne foranstaltninger kan f.eks. vedrøre hvordan farlige substanser håndteres eller at tilbyde og bære beskyttelsesudstyr.

Denne brugermanual skal kompletteres af andre instruktioner inkluderet opgaven at overvåge og rapportere uheld, som relaterer til specielle arbejdsmetoder, f.eks. organisation, arbejdsrutiner og personalets sikkerhed.

Personale som er blevet udpeget til at arbejde med maskinen skal læse brugermanualen inden arbejdets påbegyndelse, især “2 Sikkerhedsforskrifter”. Det er for sent at læse manualen efter arbejdets påbegyndelse. Dette gælder især mindre aktiviteter som at indstille udstyret, udføre servicearbejde eller at uddanne personale til arbejde med maskinen.

Af og til skal arbejdet som maskinførerne udfører kontrolleres af en overordnet, især når det vedrører ting som relaterer til bevidsthed om sikkerhed og risici.

Maskinførerne skal samle og binde langt hår op og må ikke bære løst siddende tøj eller smykker (også ringe). Der foreligger en skaderisiko hvis genstande sætter sig fast i eller trækkes ind i bevægelige dele.

Beskyttelsesbriller og høreværn skal bæres hele tiden!

Brug personligt beskyttelsesudstyr hvis det er nødvendigt eller kræves af de lokale forskrifter.

Hvis der opdages en skade på maskinen som påvirker sikkerheden eller hvis arbejdsmetoden ændres, så at sikkerheden påvirkes, skal maskinen omgående slukkes. Problemet skal afhjælpes inden maskinen tages i brug igen.

Tillæg eller ændringer på maskinen som kan påvirke sikkerheden må ikke udføres uden producentens tilladelse!

Dette gælder især fastgørelse og justering af sikkerhedsanordninger.

Reservedele skal klare de tekniske krav, som er specificeret af producenten. Dette er altid garanteret, hvis der bruges originalreservedele.

Tidsintervaller for tilbagevendende kontroller i denne brugermanual skal følges!

For at kunne udføre servicearbejde på korrekt måde skal de rigtige værktøj bruges til formålet.

Reparationer må kun udføres af Scanmaskin Sverige ABs certificerede serviceteknikere.

Under visse forhold kan slibearbejde forårsage gnister. Personale som arbejder med maskinen skal derfor være bevidste om brandrisikoen og hvordan man håndterer en brandulykke på korrekt måde.

Brug ikke maskinen i områder med meget brandfarlige stoffer og/eller eksplosive stoffer.

2.4 Personale og kvalifikationer

Ansvarsområder:

- Servicearbejde må kun udføres af uddannet personale.
- Tydeliggør ansvarsområderne for personale som kører, indstiller eller udfører service.
- Sørg for at det kun er kompetent personale som bruger eller udfører service på maskinen.
- Definer maskinførerens ansvar med hensyn til trafiksikkerhedsregler og informere denne om ikke at tage imod instruktioner fra tredje part som eventuelt ikke følger de lokale sikkerhedskrav.
- Personale som uddannes til at bruge udstyret skal være under overvågning af en erfaren person!
- Arbejde på elektrisk udstyr må kun udføres af en autoriseret elektriker eller uddannet personale under overvågning af en autoriseret elektriker og arbejdet skal være i overensstemmelse med de lokale el-sikkerhedsforskrifter.

2.5 Sikkerhed ved brug af maskinen



Tillad ingen arbejdsmetode som forhindrer sikkerhedsforanstaltninger!

Anerkendte og officielle metoder skal bruges til at sikre at maskinen bruges på en sikker måde og bedste vilkår.

Brug kun maskinen når alle sikkerhedsanordninger og relateret sikkerhedsudstyr er tilstede og funktionsdygtige!

Kontrollér maskinen visuelt for skader eller defekter mindst en gang om dagen.



Se “5.2 Daglig inspektion før brug”

Hvis maskinen ikke fungerer på korrekt måde, skal den omgående slukkes!

Afspær arbejdsfladen omkring maskinen på offentlige steder og sørg for at der opretholdes en sikkerhedsafstand på mindst 10 meter fra maskinen.

Fejl skal omgående afhjælpes.

Tænd og sluk for maskinen i overensstemmelse med denne brugermanual.

Inden maskinen tændes skal man sørge for at ingen kan blive udsat for fare, når maskinen starter.

Maskinen må kun startes i oprejst stilling.

Sluk ikke og fjern ikke ventilationsrelaterede anordninger når maskinen er i gang!

Alle personer i maskinens nærhed skal bære høreværn, beskyttelsesbriller og sikkerhedssko. Udover dette skal maskinføreren bære tætsiddende beskyttelsestøj.

Forlængerledninger skal være mærket og godkendt til maskinens totale el-forbrug og følge almene og lokale bestemmelser.



Se også "2.6 El-sikkerhed".

Sørg for at der ikke ligger affald på arbejdsfladen.

Undersøg arbejdsfladen for skruer eller andre hårde genstande som sidder i fladen. Brug ikke maskinen hvis der sidder fremmede genstande fast i fladen. Disse genstande skal fjernes inden maskinen bruges.

2.6 El-sikkerhed



Kraftkilden skal være udstyret med sikringer ifølge “1.1 Elektriske specifikationer”. Forlængerledninger skal være mærket og godkendt til maskinens totale el-forbrug og følge almene og lokale bestemmelser. Tilslut aldrig maskinen til en kraftkilde som ikke har beskyttelses-jord!

Arbejde på elektrisk udstyr må kun udføres af en autoriseret elektriker eller uddannet personale under overvågning af en autoriseret elektriker i overensstemmelse med de lokale el-sikkerhedsforskrifter.

Forlængerledninger skal være mærket og godkendt til maskinens totale el-forbrug og følge almene og lokale bestemmelser.

Det elektriske udstyr på arbejdsstedet skal efterses regelmæssigt. Defekter som løse forbindelser eller brændte ledninger skal omgående afhjælpes. Kontakt en elektriker eller kundetjenesten.

Arbejdsområdet skal afspærres for tredje part. Følg de lokale el-sikkerhedsforskrifter når der udføres arbejde på maskinen. Efterlad aldrig en maskine uden opsyn. Brug kun isoleret værktøj.

Påbegynd kun arbejdet hvis du har kendskab til de lokale el-sikkerhedsforskrifter.

Kontrollér at spændingen er korrekt ifølge “1.1 Elektriske specifikationer” inden maskinen tændes.

2.6.1 Ledninger



Brug kun ledninger som er mærket og specificeret ifølge specifikationerne i "1.1 Elektriske specifikationer". Brug ikke for lange ledninger. Hvis der er brug for en lang tilslutning, så anbefaler vi en ledning til højere strøm som går til en strømtavle nær maskinen. Læg aldrig ledningen i en ring da den kan overhedes. Se "Figur 2-1".

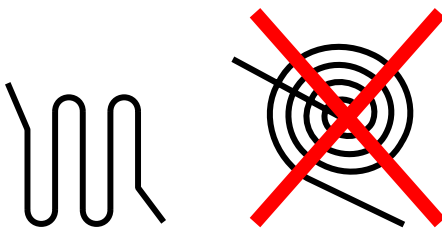

Figur 2-1 Anbefalinger til hvordan lange ledninger bruges.

2.6.2 Brug af generator



Generatoren skal være udstyret med beskyttelsesjord og bruges ifølge de nuværende EN-VDE-direktiver (dette hentyder især til beskyttelsesjord-tilslutningen) for at sikre at alle sikkerhedsanordninger virker og eliminere potentiel skade på elektriske komponenter.

2.7 Definition af "Slukket og sikker stilling"

Maskinen er i en sikker stand, når den ikke kan udgøre en fare.

Hvordan man omstiller maskinen til "Slukket og sikker stilling"

1. Sluk for maskinen
2. Hvis der bruges en støvsuger, skal den slukkes
3. Vent til alle bevægelige dele er standset helt
4. Frakobl hovedstrømmen
5. Du skal forsikre dig, at der ikke kan forekomme utilsigtet start



Frakobl altid hovedstrømmen til maskinen ved maskinen for at forhindre at en person utilsigtet tilkobler hovedstrømmen, mens der udføres arbejde på maskinen.

2.8 Sikkerhed som vedrører service

Sæt maskinen i slukket og sikker stilling inden der påbegyndes arbejde på maskinen.



Læs "2.7 Definition af "Slukket og sikker stilling"".

Arbejd aldrig på maskinen når hovedstrømmen er tilsluttet! Alle dele skal være standset helt inden arbejde påbegyndes!



Når maskinen ligger ned bagud, kan den vippe tilbage til dens oprejste stilling. Vær nøje med at forhindre at dette sker, så der ikke sker personskader eller materielle skader.



Når maskinen har været brugt, så kan segmenterne, Scan-On-fæsteskiverne og andre dele af maskinen være varme. Udvis forsigtighed for at forhindre forbrændinger.



Maskinen må ikke være tilkoblet en strømkilde, når den vaskes.



Se også "5.5 Rengøring af maskinen".

2.9 Sikkerhed under transport



Tag altid værktøjet af inden transport da de kan falde af eller forårsage skade på underlaget.

2.9.1 Manuel transport



Når maskinen transporteres manuelt skal man være opmærksom på skråninger og kanter. Følg arbejdspladsens lokale færdselsregler for at undgå ulykker. Hvis disse regler ikke følges, kan det medføre personskade eller materielle skader.

2.9.2 Løftning



Maskinen skal sikres ifølge de lokale sikkerhedsregler inden den løftes. Der må ikke opholde sig nogen under en løftet maskine! Maskinen skal løftes i overensstemmelse med instruktionerne i "3.3 Løftning". Vær opmærksom på maskinens tyngdepunkt inden den løftes. Hvis disse regler ikke følges, kan det medføre personskade eller materielle skader. Brug kun remme og stropper som er godkendt til den korrekte vægt og løftemetode!

2.9.3 Inde i et køretøj



Maskinen skal sikres ifølge de lokale transportsikkerhedsforskrifter inden maskinen transporteres inde i et køretøj. Hvis maskinen ikke sættes fast, kan det medføre personskade eller materielle skader.

3 Transport

3.1 Sikkerhedsforanstaltninger

 Læs "2.9 Sikkerhed under transport" inden transport af maskinen påbegyndes.

3.2 Manuel transport

- Frigør værktøjet ifølge instruktionerne i "4.14 Værktøjsskift".
- Tryk håndtaget ned så slibehovedet løfter ca. 10 cm fra jorden.
- Før maskinen i den ønskede retning.

3.3 Løftning



Inden løft af maskinen påbegyndes, læs "2.9.2 Løftning".

- Frigør værktøjet ifølge instruktionerne i "4.14 Værktøjsskift".
- Sæt de remme som bruges til at løfte maskinen fast ved de to løftepunkter som vises i "Figur 3-1".
- Løft maskinen.



Figur 3-1 Løftepunkter SC-450 standard

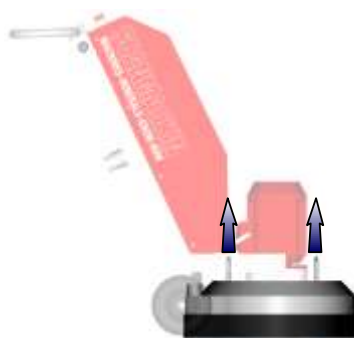

Figur 3-2 Løftepunkter SC-450 NS

3.4 Deling af maskine

Hvis maskinen skal transporteres i et trangt sted kan den deles i to dele.

På hver side af motordelen er der to stifter som igen har hver sin hårnålestift. For at dele maskinen skal motoren først frakobles ved skillekontakten, tag derefter hårnålestifterne ud og derefter stifterne ud. Vær forsigtig så vognen ikke falder bagud.

3.5 Inde i et køretøj

- Frigør værktøjet ifølge instruktionerne i "4.14 Værktøjsskift".
- Sikr maskinen inde i køretøjet.



Sikr maskinen ifølge de lokale sikkerhedsforskrifter.

4 Håndtering

4.1 Forsigtighedsforanstaltninger



Alle maskiner som ikke bruges ifølge sikkerhedsforskrifterne kan være farlige at bruge, indstille eller udføre service på. Arbejdslederen er ansvarlig for at sikkerhedsforskrifterne følges, både under brug og service af maskinen samt at sikkerhedsfunktioner som følger med maskinen bruges. Arbejdslederen er også ansvarlig for at stille passende øvrigt sikkerhedsudstyr til rådighed!

Brug aldrig maskinen uden korrekt værktøj.

Beskyttelsesbriller og høreværn skal bæres hele tiden.

Maskinen må kun startes i oprejst stilling.

Sørg for at der ikke ligger affald på arbejdsfladen.

Undersøg arbejdsfladen for skruer eller andre hårde genstande som sidder i fladen. Brug ikke maskinen hvis der sidder fremmede genstande fast i fladen. Disse genstande skal fjernes inden maskinen bruges.



Læs "2 Sikkerhedsforskrifter" inden maskinen tages i brug.

4.2 Maskinens funktion

Gearhuset har tre slibeskiver som roterer i gearhusets modsatte retning. Hver slibeskive er udstyret med en Scan-On-fæsteskive som holder værktøjet som bruges. Se "Figur 4-1".



Figur 4-1 Illustrerer hvordan slibeskiverne bevæger sig i forhold til slibehovedet.



Maskinen er udstyret med en termisk beskyttelse som slukker motordriften ved høje temperaturer. Vent i mindst 15 minutter inden maskinen tages i brug igen!

4.3 Manøvregrab SC-450 Standard

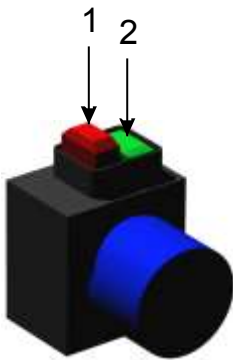

Figur 4-2 SC-450 Standard manøvregrab

Nummer	Funktion	Beskrivelse
1	Stop	Standser SC-450
2	Start	Starter SC-450

Tabel 4-1 Beskrivelse af manøvregrab

4.4 Opstart



Læs "4.1 Forsigtighedsforanstaltninger" inden maskinen startes.

Hvordan man starter maskinen

- Sørg for at maskinen er udstyret med korrekt værktøj
- Sørg for at hovedstrømmen og slanger til støvsuger er tilsluttet til maskinen
- Hvis der bruges en støvsuger, skal den startes
- Tryk håndtaget ned så slibehovedet løftes ca. 10 cm fra arbejdsfladen
- Tryk på startknappen (2)
- Sænk slibehovedet ned mod arbejdsfladen
- Slip aldrig håndtaget når maskinen er i drift

4.5 Stop

Hvordan man standser maskinen

- Tryk på stopknappen (1)
- Vent til maskinen er standset helt inden håndtaget slippes
- Hvis der bruges en støvsuger, skal den slukkes

4.6 Kontrolpanel SC-450NS



Figur4-3 SC-450NS kontrolpanel

Nummer	Tekst	Beskrivelse	Artikelnummer
1	L/R	Vælger rotationsretning	596001
2	SPEED	Vælger hastighed ⁵	596009
3	EMERGENCY STOP	Nødstop	596003
4	STOP	Standser maskinen	596007
5	START	Starter maskinen	596006

Tabel 4-2 Beskrivelse af kontrolpanelet.

⁵ Se ”Fel! Hittar inte referenskölla.Fel! Hittar inte referenskölla.” for at se hvilke hastigheder der gælder for din maskine.

4.6.1 Vandtank SC-450NS



For at øge vandstrømmen drejes regulatoren venstre om. Regulatoren vil bevæge sig udad.



For at mindske vandstrømmen drejes regulatoren højre om. Regulatoren vil bevæge sig indad.



For hurtigt at stoppe vandstrømmen trykkes på knappen på regulatoren. Dette frigør regulatoren og en fjeder trækker den ind.



For at sikre at regulatoren er helt lukket spændes den en lille smule.

For at tømme tanken inden liggende transport indstilles regulatoren på maksimum og lad vandet løbe ud. Sørg for at tanken er tømt inden liggende transport.

Tøm tanken inden langtidsopbevaring.

4.7 Opstart SC-450NS



Læs ”4.1 Forsigtighedsforanstaltninger” inden maskinen startes.

Hvordan man starter maskinen

- Sørg for at maskinen er udstyret med korrekt værktøj
- Sørg for at hovedstrømmen og slanger til støvsuger og vand er tilsluttet til maskinen
- Hvis der bruges en støvsuger, skal den startes
- Tryk håndtaget ned så slibehovedet løftes ca. 10 cm fra arbejdsfladen
- Sørg for at ”EMERGENCY STOP” (3) er tilbagesluttet.
- Tryk på ”START” (5).
- Sænk slibehovedet ned mod arbejdsfladen
- Slip aldrig håndtaget når maskinen er i drift

Hvis maskinen har været nødstoppet så skal man trykke på ”STOP” (4) inden man starter den for at tilbageslutte den.

4.8 Nødstop / tilbagestilling SC-450NS

Brug nødstop til hurtigt at standse maskinen for at forhindre ulykker eller skader.

Tilbagestilling:

- Drej "EMERGENCY STOP" (3) i urets retning til den kører op.
- Tryk på "STOP" (4)

Maskinen er nu klar til at blive startet igen.

4.9 Stop SC-450 NS

Hvordan man standser maskinen

- Tryk på "STOP" (4)
- Vent til maskinen er standset helt inden håndtaget slippes.
- Sluk for støvsugeren hvis den bruges.

4.10 Hastighedsregulering SC-450NS

Brug "SPEED" (2) til at justere rotationshastigheden på slibeskiverne i de interval som beskrives i "1.1 Elektriske specifikationer".

4.11 Rotationsretning SC-450NS

Brug "L/R"-omskifteren (1) til at skifte rotationsretning på slibeskiverne. Maskinen standser og starter automatisk i den valgte retning.

4.12 Slukket og sikker stilling

Når der udføres arbejde på maskinen, enten servicearbejde eller værktøjsskift, så skal maskinen sættes i "Slukket og sikker stilling" Se "2.7 Definition af "Slukket og sikker stilling"" for mere information.

4.13 Slibning

Se "Slibeguiden" for instruktioner og information om slibning.

4.14 Værktøjsskift



Inden værktøj skiftes, læs "2.8 Sikkerhed som vedrører service".

Denne illustration viser hvordan man skifter værktøj



Figur 4-4 Hvordan man fæster slibesegmenterne på Scan-On-fæsteskiven

- 1 Sæt værktøjet ind i den bredeste ende
- 2 Træk værktøjet udad fra skiven
- 3 Værktøjet sidder nu fast på Scan-On-fæsteskiven

For at forsikre dig at værktøjet sidder på plads så kan der bruges en lille plasthammer til forsigtigt at banke værktøjet fast. Plasthammeren kan også bruges til at fjerne et værktøj som sidder fast.

5 Service

5.1 Sikkerhedsforanstaltninger

Sæt maskinen i ”slukket og sikker stilling” inden der påbegyndes arbejde på maskinen.



Se “2.7 Definition af ”Slukket og sikker stilling””.



Læs “2.6 El-sikkerhed” inden arbejde på maskinen påbegyndes.

Arbejd aldrig på maskinen når hovedstrømmen er tilsluttet!

Alle dele skal være standset helt inden arbejde påbegyndes!



Når maskinen ligger ned på bagsiden, kan den vippe tilbage til dens oprejste stilling. Vær nøje med at forhindre at dette sker, for at sikre at der ikke sker personskader eller materielle skader.



Når maskinen har været i brug, så kan segmenterne, Scan-On-skiverne og andre dele være varme. Vær forsigtig for at forhindre forbrændinger.

Indjustering, service- og inspektionsarbejde skal udføres af kvalificeret personale.



Maskinen må ikke have hovedstrømmen tilkoblet når den vaskes.

5.2 Daglig inspektion før brug

Kontrollér følgende ting inden maskinen tages i brug

- Kontrollér at hjulene ikke er beskadiget.
- Kontrollér slibehovedets skiver og nav for beskadigelse.
- Kontrollér slibehovedet, snavs som sidder mellem Scan-On-fæsteskiven og slibeskivenavet kan mindske slibehovedets fleksibilitet.
- Hvis skruer sidder løst skal de spændes.
- Se hele maskinen efter så der ikke er opstået anden skade.

5.3 Service- og inspektionsskema

Dagligt	<ul style="list-style-type: none"> ▪ Kontrollér hjulene ▪ Kontrollér slibehovedet ▪ Efterse maskinen for skader
12 timer efter service	<ul style="list-style-type: none"> ▪ Efterspænd samtlige skruer

5.4 Skift af Scan-On-fæsteskiye

Følg disse trin for at skifte Scan-On-fæsteskiye

- Sørg for at maskinen er sat i ”slukket og sikker stilling” som beskrevet i ”2.7 Definition af ”Slukket og sikker stilling””
- Læn maskinen bagud og sikr den.
- Fjern eventuelle værktøj ifølge ”4.14 Værktøjsskift”.
- Løsn de tre skruer som holder Scan-On-skiven fast.
- Skift Scan-On-fæsteskiye.
- Det anbefales at der bruges nye skruer til at sætte den udskiftede Scan-On-fæsteskiye fast.
- Det anbefales også at man bruger kobberpasta i forsænkningen.
- Skru alle skruer fast med hånden og sørg for at de er ordentligt spændt.

5.5 Rengøring af maskinen

Inden rengøring af maskinen påbegyndes skal man sørge for at den er i ”slukket og sikker stilling”.

Hovedstrømmen må ikke være tilsluttet til maskinen under rengøringen.

Brug ikke højtrykrenser til at rengøre maskinen. Vand og sæbe anbefales.

5.6 Fejlsøgning

5.6.1 Almindelige problemer

Symptom	Årsag	Afhjælpning	A ⁶
Maskinen startar ikke	<ul style="list-style-type: none"> ▪ Kraftkilden er strømløs 	<ul style="list-style-type: none"> ▪ Kontrollér sikringerne ved arbejdsstedets kraftkilde. ▪ Kontrollér ledningerne. ▪ Kontrollér at hovedstrømmen når frem til maskinen og har korrekt spænding. 	O E E
Maskinen kører kun når den grønne knap er trykket ned.	<ul style="list-style-type: none"> ▪ Motoren er overhedet 	<ul style="list-style-type: none"> ▪ Vent til motoren er kølet af 	O
	<ul style="list-style-type: none"> ▪ Styreboksen er blevet skadet 	<ul style="list-style-type: none"> ▪ Udskift styreboksen 	S
Maskinen er sløj og kan ikke så meget	<ul style="list-style-type: none"> ▪ Der er sket et spændingsfald 	<ul style="list-style-type: none"> ▪ Kontrollér sikringerne ved arbejdsstedets kraftkilde. ▪ Kontrollér ledningerne. ▪ Kontrollér at hovedstrømmen når frem til maskinen og har korrekt spænding. 	O E E
		<ul style="list-style-type: none"> ▪ Sørg for at der ikke er brugt for lange ledninger. Hvis der er brug for en meget lang ledning, så kan man bruge en ledning til højere strøm som går til en strømtavle nær maskinen. 	O
Maskinen vibrerer meget	<ul style="list-style-type: none"> ▪ Slibehastigheden er for høj 	<ul style="list-style-type: none"> ▪ Sænk hastigheden 	O
	<ul style="list-style-type: none"> ▪ Værktøjet er beskadiget 	<ul style="list-style-type: none"> ▪ Kontrollér værktøjet ▪ Udskift hvis nødvendigt 	O O

5.6.2 Alarm- og fejlkoder SC-450NS

Kode	Beskrivelse	Årsag	Afhjælpning	A ⁶
A2001	Overstrøm	<ul style="list-style-type: none"> En af de tre faser mangler fra strømkilden Der er sket et spændingsfald 	<ul style="list-style-type: none"> Kontrollér strømkildens sikringer Kontrollér ledningerne Kontrollér at hovedstrømmen når frem til alle faser og har korrekt spænding ved maskinen. Sørg for at ledningen ikke er for lang. Hvis der behøves en lang ledning, skal der bruges en grovere ledning og sættes et el-skab nærmere maskinen. 	O E E O
		<ul style="list-style-type: none"> Omgivelsestemperaturen er for høj. Når omgivelsestemperaturen er over 40°C så vil omformeren mindske den maksimale udgangsstrøm 	<ul style="list-style-type: none"> Kontrollér ventilatorerne Kontrollér ventilatorenes filter 	O O
A2002	Overspænding	<ul style="list-style-type: none"> Kraftkilden har spændingsspidser 	<ul style="list-style-type: none"> Kontrollér kraftkilden 	E
A2003	Underspænding	<ul style="list-style-type: none"> En af de tre faser mangler fra strømkilden Der er sket et spændingsfald 	Se A2001	
A2006	Hastighedsreferencefejl	<ul style="list-style-type: none"> Potentiometeret på kontrolpanelet er beskadiget 	<ul style="list-style-type: none"> Kontrollér potentiometeret Udskift hvis nødvendigt 	S S
A2009	Overhedning	<ul style="list-style-type: none"> Den interne temperatur overstiger 120°C. Dette kan skyldes nedsat ventilation i el-skabet. 	<ul style="list-style-type: none"> Kontrollér ventilatorerne Kontrollér ventilatorenes filter Kontakt Scanmaskin Sverige AB 	O O
A5001	Intern fejl	Kontakt Scanmaskin Sverige AB		
F0001	Overstrøm	Se A2001		
F0002	Overspænding	Se A2002		
F0003	Overhedning	<ul style="list-style-type: none"> Den interne temperatur overstiger 135°C. Dette kan skyldes nedsat ventilation i el-skabet. 	Se A2009	
F0004	Motoren kortsluttet	<ul style="list-style-type: none"> Motorens kabel er beskadiget. Motoren er beskadiget. 	<ul style="list-style-type: none"> Kontrollér motorens kabel Kontrollér konnektoren Kontakt Scanmaskin Sverige AB 	E E
F0006	Underspænding	Se A2003		
F0007	Hastighedsreferencefejl	Se A2006		
F0016	Jord(ings)fejl	<ul style="list-style-type: none"> Motorens kabel er beskadiget Motoren er beskadiget Der er kommet vand i motoren 	<ul style="list-style-type: none"> Kontrollér motorens kabel Kontrollér konnektoren Kontakt Scanmaskin Sverige AB 	E E
F0018	Intern fejl	Kontakt Scanmaskin Sverige AB		
F0021		Kontakt Scanmaskin Sverige AB		
F0022	Fasefejl	Se A2003		
F0034	Motorfasefejl	<ul style="list-style-type: none"> En af de tre faser til motoren mangler. Dette kan skyldes skade på motorkablet eller motoren. 	<ul style="list-style-type: none"> Kontrollér motorens kabel Kontrollér konnektoren Kontakt Scanmaskin Sverige AB 	E E

Tabel 5-1 Fejlkoder

Alarmkoder begynder med “A” og fejlkoder med “F”. Maskinen kan bruges ved en alarm, men ikke ved en fejl.

Følgende tabel beskriver hvem der må gøre hvad, når det drejer sig om servicearbejde.

Forkortelse	Person
O	Maskinfører
E	Elektriker
S	Scanmaskin certificeret servicetekniker

Tabel 5-2 Beføjelse til servicearbejde

6 Reservedele

6.1 Maskinhus

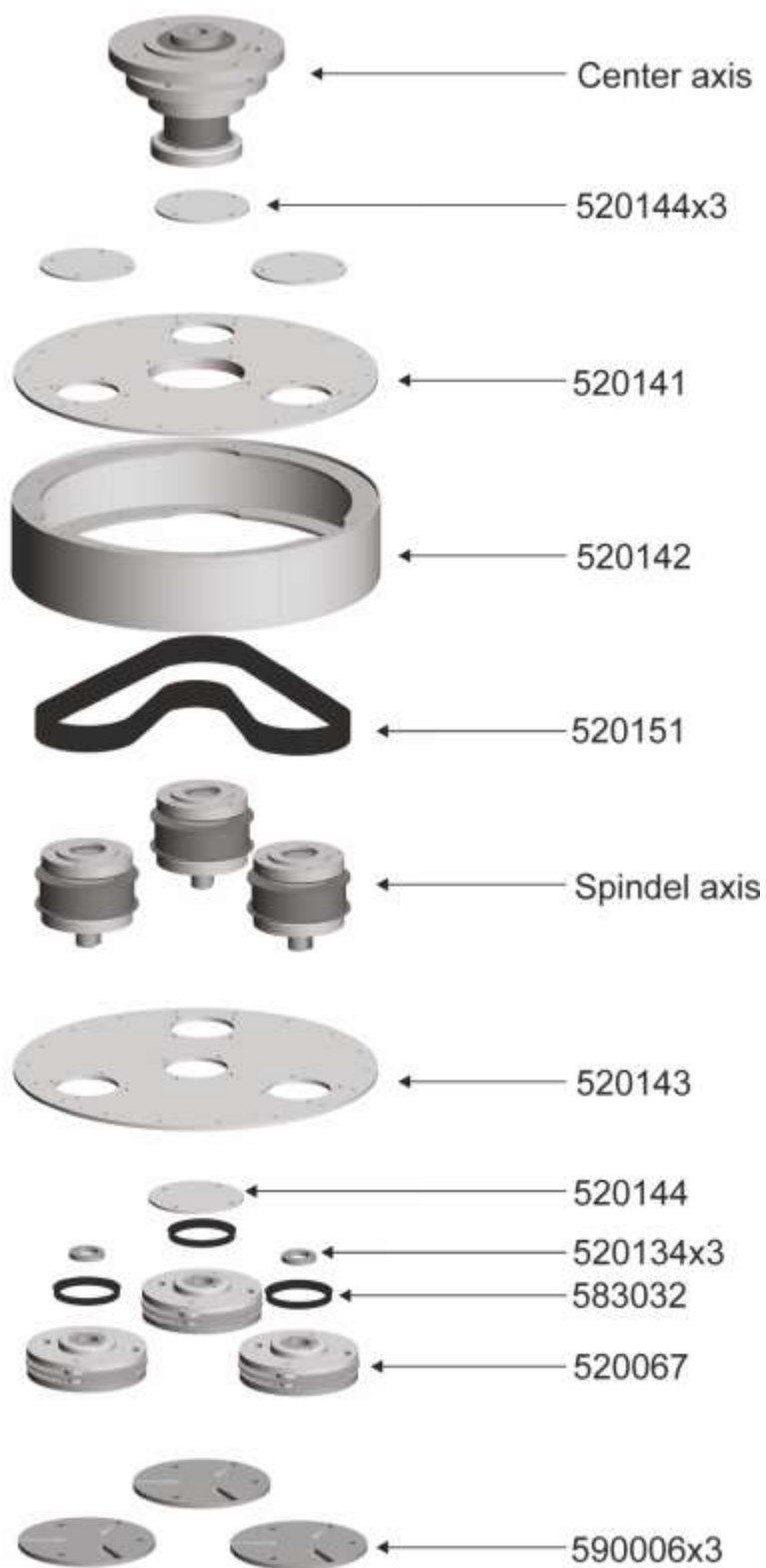

6.2 Centeraxsel



6.3 Slibeaksel

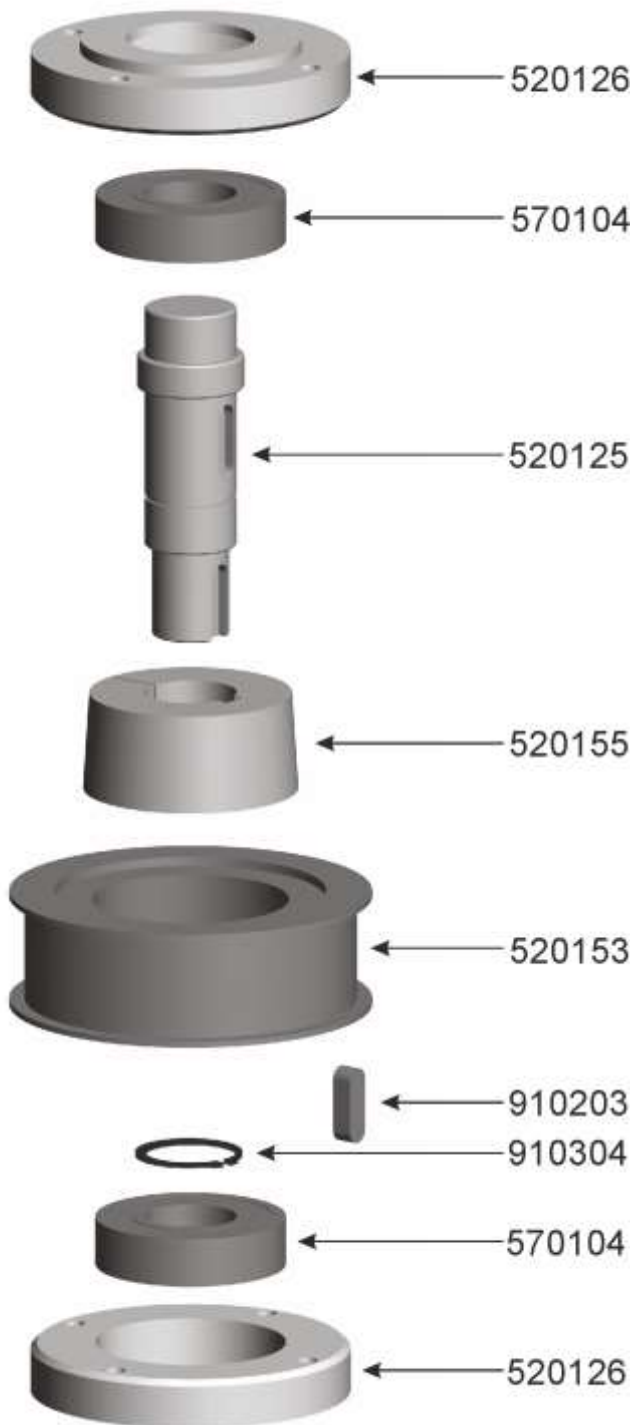

6.4 Slibehoved



7 Garanti

Dette produkt fra Scanmaskin Sverige AB har tolv måneders garanti.

Hvis produktet ikke skulle fungere tilfredsstillende inden for denne tid, vil Scanmaskin sørge for, at produktet gøres funktionsdygtigt til den normale anvendelse, som produktet er tiltænkt – uden omkostninger til arbejde eller reservedele, i henhold til følgende vilkår:

1. Garantien gælder kun personer, som lovligt har ejendomsret til udstyret i garantiperioden.
2. Producentens ansvar er begrænset til reparation af defekte dele eller udskiftning af disse efter producentens bedømmelse. Transportomkostninger og -risici, samt demontering og geninstallation af produktet/produkterne, samt andre direkte eller indirekte omkostninger, som hænger sammen med den aktuelle reparation, dækkes ikke af denne garanti.
3. Periodiske kontroller, justeringer, vedligeholdelsesarbejder og ændringer dækkes ikke af garantien.
4. Scanmaskin er ikke ansvarlig for eventuelle skader på slibeskiver eller andet lignende udstyr.
5. Garantien gælder udelukkende fejl i materialer og konstruktion og gælder ikke i følgende tilfælde:
 - a. Skader forårsaget ved ulykker, forsømmelighed, ændringer, anvendelse af reservedele eller slibeværktøjer, som ikke er originale dele/komponenter, eller forkert anvendelse og installation.
 - b. Skader forårsaget af lynnedslag, vand, brand, hærværk, forkert netspænding, forkert ventilation eller anden årsag, som ligger uden for producentens kontrol.
6. Scanmaskin forbeholder sig ret til at ændre konstruktionen eller foretage forbedringer uden pligt til at ændre tidligere fremstillede produkter.
7. Alle garantireparationer skal udføres af Scanmaskin eller af et Scanmaskin autoriseret reparationsværksted. Omkostninger til reparationer, som udføres af et ikke-godkendt værksted, erstattes ikke af Scanmaskin. Hvis en sådan reparation skulle medføre skade på produktet dækkes den ikke af garantien.

8 EF-Deklaration

EU-overensstemmelseserklæring

Producent Scanmaskin Sverige AB
Adresse Heljesvägen 10
427 36 Lindome / Göteborg
Sverige

Produkt Slibemaskine

Produktnavn Scan Combiflex 450
Scan Combiflex 450NS

Serienummer _____

Ovenstående produkt er i overensstemmelse med følgende EU-direktiver

Maskindirektiv 2006/42/EF
EMC 2004/108/EF
LVD 2006/95/EF
Harmoniserede standarder EN ISO 12100:2010
EN ISO 60204-1

Udstedelsessted Lindome / Göteborg / Sverige

Autoriseret repræsentant Claes-Göran Bergstrand
Administrerende direktør

Scanmaskin Sverige AB
01-01-2010

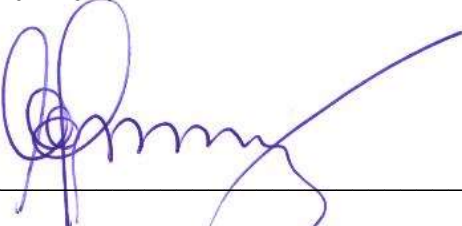

Claes-Göran Bergstrand
Administrerende direktør

9 Alfabetisk register

INDEX

10 Kontakt

Sverige Hovedkontor

Heljesvägen 10
Box 187
S-437 22 Lindome

Telefon: +46 (0) 31 99 49 70
Fax: +46 (0) 31 99 48 70
E-mail: info@scanmaskin.se
Hjemmeside: www.scanmaskin.se

Danmark

Torvegade 22
DK-7330 Brande

Telefon: +45 97 18 00 58
Fax: +45 97 18 45 58
E-mail: info@scanmineral.dk
Hjemmeside: www.scanmaskin.se

Norge

Postboks 6, Furuset, N-1001 Oslo
Tomtveien 12
N-2015 Leisund

Telefon: +47 -63 87 60 00
Fax: +47 -63 87 60 01
E-mail: info@scanmaskin.no
Hjemmeside: www.scanmaskin.no

Finland

Raudoittajantie 3A
FIN-06450 Porvoo / Borgå

Telefon: +358 10 292 4700
E-mail: info@scanmaskin.fi
Hjemmeside: www.scanmaskin.fi

USA

1407 132nd Avenue Northeast, Suite 8
Bellevue, Washington, 98005

Phone: +1 425 209 0147
E-mail: info@scanmaskin.com
Hjemmeside: www.scanmaskin.com

Dear Customer!

Thank you for choosing Scanmaskin as your supplier.
We wish you all the best with your new Scan Combiflex™ 450 and hope that it meets your expectations.

Scanmaskin Sweden AB



Claes-Göran Bergstrand
Managing Director

Address:

Scanmaskin Sweden AB

Box 187

SE-437 22 Lindome / Gothenburg

Sweden

Telephone: +46 (0) 31 99 49 70

Fax: +46 (0) 31 99 48 70

<http://www.scanmaskin.com/>

Important Information!

This User Guide only concerns the floor grinding machines “**Scan Combiflex 450**” hereby referred to as “**SC-450**”. SC-450 may only be used for grinding horizontal surfaces approved by Scanmaskin Sweden AB.

If SC-450 is used for other purposes or handled in ways other than that described in this User Guide, Scanmaskin Sweden AB disclaims all responsibility.

Especially note the section “2 *Safety Regulations*”. Read the User Guide before using the floor grinding machine SC-450. The spare parts, grinding discs used on SC-450 must be approved by Scanmaskin Sweden AB.

Table of Contents

1	Specifications.....	40
1.1	Electrical specifications.....	40
1.2	Mechanical specifications.....	41
1.3	Tools.....	42
1.4	Range of application.....	43
1.5	Scope of supply.....	43
1.6	Overview.....	44
2	Safety Regulations.....	46
2.1	Legend.....	46
2.2	Safety precautions.....	46
2.3	Organizational measures.....	47
2.4	Personnel selection and qualification.....	48
2.5	Safety regarding operation of machine.....	48
2.6	Electrical safety.....	49
2.6.1	Cables.....	50
2.6.2	Using a generator.....	50
2.7	Definition of the “Safety off position”.....	50
2.8	Safety regarding maintenance.....	51
2.9	Safety regarding transport.....	51
2.9.1	Manual transport.....	51
2.9.2	Lifting.....	52
2.9.3	Inside vehicles.....	52
3	Transportation.....	53
3.1	Safety precautions.....	53
3.2	Manual transportation.....	53
3.3	Lifting.....	53
3.4	Separation of machine.....	53
3.5	Inside vehicles.....	54
4	Operation.....	55
4.1	Precautions.....	55
4.2	Machine functions.....	55
4.3	Control device SC-450.....	56
4.4	Start up.....	56
4.5	Stop.....	56
4.6	Control panel SC 450 NS.....	57
4.6.1	Water tank SC-450 NS.....	57
4.7	Start up the SC-450 NS.....	58
4.8	Emergency stop / Reset SC-450 NS.....	58
4.9	Stop the SC-450 NS.....	58
4.10	Grinding speed SC-450 NS.....	58
4.11	Rotation direction SC-450 NS.....	58
4.12	Safety off position.....	59
4.13	Grinding.....	59
4.14	Changing tools.....	59
5	Maintenance.....	60
5.1	Precautions.....	60
5.2	Daily inspection prior to operation.....	60

5.3	Maintenance and inspection list	60
5.4	Grinding disc replacement / assembly	61
5.5	Cleaning the machine	61
5.6	Trouble shooting	61
5.6.1	Common faults	61
5.6.2	Error codes SC-450 NS	62
6	Spare parts	63
6.1	Gear barrel	63
6.2	Center axis	65
6.3	Spindel axis	67
6.4	Grinding head	69
7	Warranty	71
8	EU Declaration	72
9	Alphabetical reference	73
10	Contact information	74

1 Specifications

The SC-450 is available with different power inputs. This is described in the different sections later on in this chapter.

1.1 Electrical specifications

To find the specifications that apply to your machine, check the information plate on the machine.



Never connect the SC-450 to any other voltage or number of phases than described in this specification.



The power source must be fused according to “External fuse” in this specification; also the cables used must be marked and rated in accordance with the fuse used. Failure to comply with the correct fuses may cause fire or injuries.

Power choice ¹	230 V 1~ ²	230 V NS	110 V 1~
Power	1.5 kW (2 hp)	2.2 kW (3 hp)	1.5 kW (2 hp)
Current	8.7 A	12.9 A	18.5 A
Voltage	200 – 240 V 1~	200 – 240 V 1~	100 – 130 V 1~
Frequency	50 Hz +/- 5%	50 Hz +/- 5%	60 Hz +/- 5%
External fuse ³	10 A	13 A	20 A
Power inlet ⁴	CEE 7/7 – 250V 16A + PE	CEE 7/7 – 250V 16A + PE	NEMA 5-20 – 125V 20A + PE

Table 1-1 Electrical specifications

All models are CE-marked.



If using a generator see “2.6.2 Using a generator”

¹ This refers to different power choices. Note that a SC-450 made for one choice of power must be used with the particular choice.

² Standard

³ Maximum current for the fuses used in the power source (*i.e. the distribution box*).

⁴ This is the standard inlet used. Machines sold outside of EU will be shipped either with a local standard inlet or an adapter.

1.2 Mechanical specifications

Model	SC-450	SC-450 2,2 NS / 2.2kW
Grinding diameter	450 mm 17.7"	450 mm 17.7"
Grinding plate diameter	150 mm 5.9"	150 mm 5.9"
Grinding plate speed	950 rpm	950 rpm
Mass	90 kg 198 lbs	100kg 220 lbs
Gear barrel	Free running 	Free running 

Table 1-2 Mechanical specifications

Dimensions of SC-450

Width	460 mm	18.1"
Height	1030 mm	40.6"
Depth	810 mm	31.9"

Dimensions of shipping box

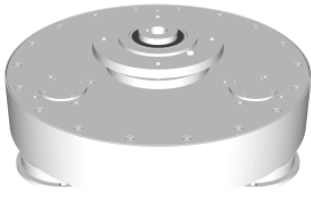
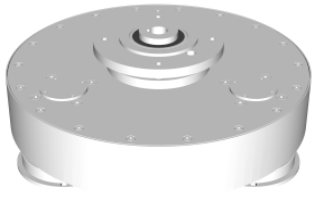
Width	610 mm	24.0"
Height	1430 mm	56.3"
Depth	810 mm	31.9"

Ambient temperature during operation	-20°C to +40°C	-4°F to 104°F
Ambient temperature during storage	-20°C to +70°C	-4°F to 158°F



Figure 1-1 Standard SC-450

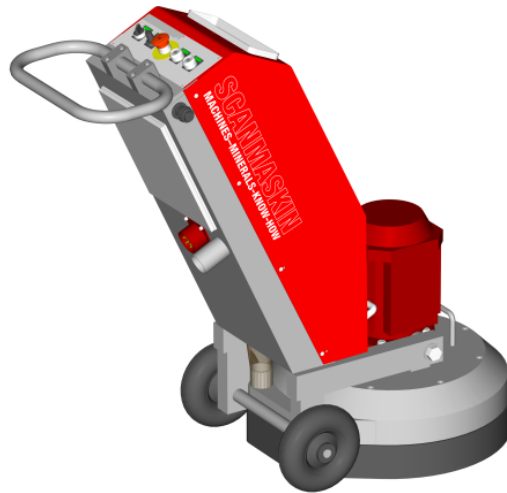

Figur 1-2 SC-450 NS

1.3 Tools



The machine must be equipped with tools approved by Scanmaskin Sweden AB before operation.



See “Grinding guide” for information about available tools and “4.14 Changing tools” for information about how to change the tools.

The tools are fitted using the Scan-On system for easy fitting.

Available tools

- Diamond tools
- SC-Tiger PCD
- Sand paper

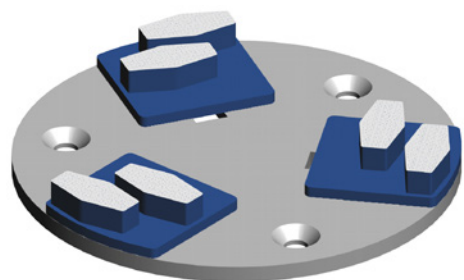

Figure 1-2 Scan-On plate with tools fitted.

1.4 Range of application



SC 450 is exclusively designed to process horizontal surfaces. SC 450 must not be used for other purposes than stated in this user guide. The manufacturer will not be liable for damage or injury resulting from incorrect usage of SC 450. Failure to follow the directions in this user guide will void the warranty.

Typical applications

- Removal of old coatings, carpets, putty from hard surfaces
- Removal of undulated concrete surfaces
- Preparation of the surface for coatings
- Polishing of the surface
- Removal of coating defects
- Removal of glue residues

SC 450 is recommended from small to medium sized work sites.

1.5 Scope of supply

The following parts are included with the standard SC 450 grinding machine:

- User Guide
- 5 mm hexagon socket key

Machines sold outside of Europe will be either equipped with a local standard connector for the power inlet or the mating connector will be included and fitted at the main power inlet.



Read “2.6 Electrical safety” before connecting any included connectors.

1.6 Overview

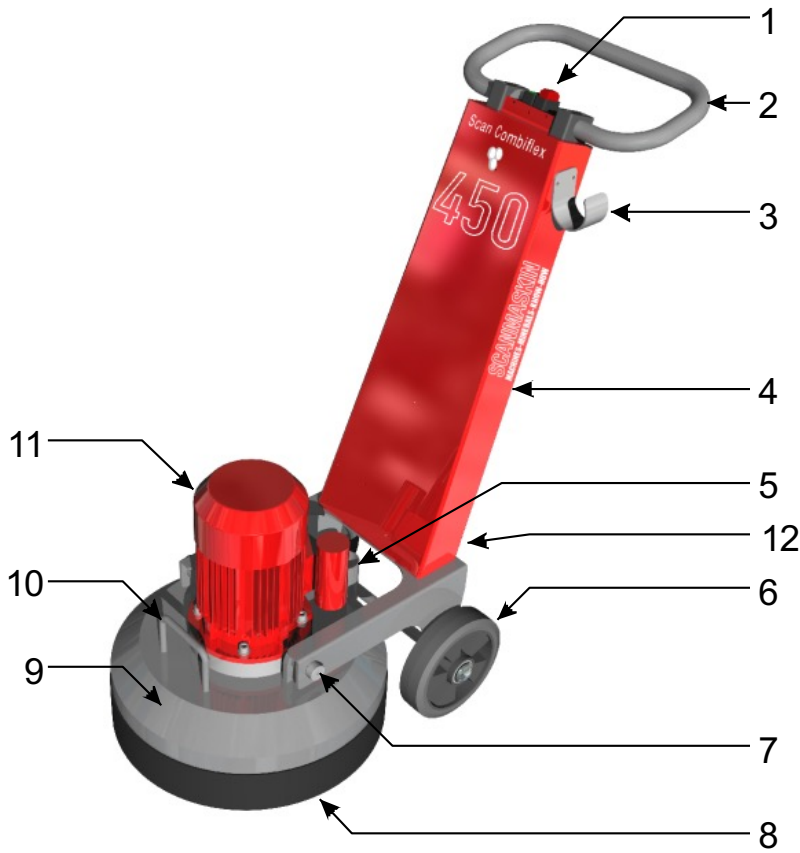

Figure 1-3 SC 450 overview

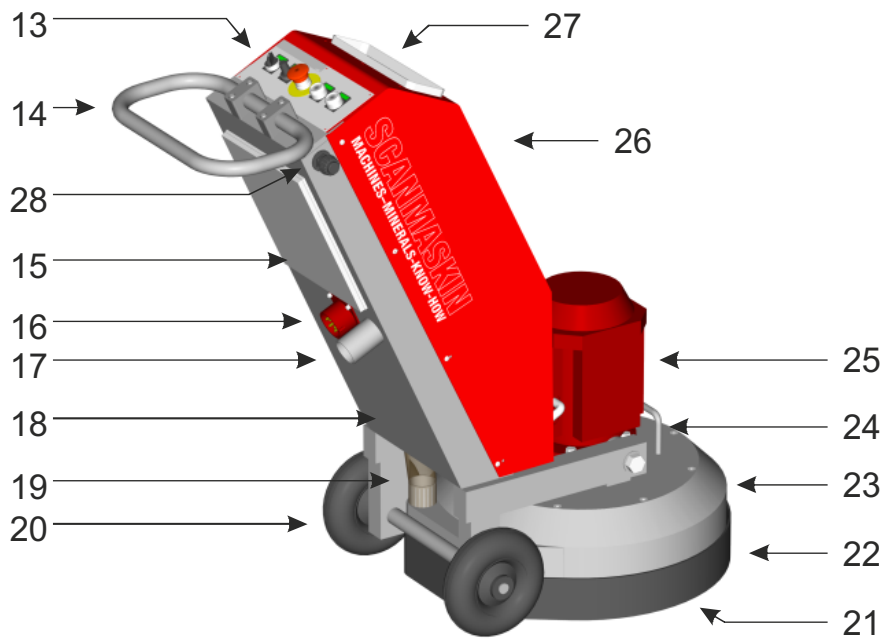
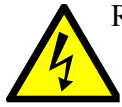

Figure 1-4 SC 450NS overview

Item	Description	Reference
1	Control device	<i>4.3 Control devic</i>
2	Handle	
3	Dust collector hose holder	
4	Frame	
5	Dust collector outlet	
6	Wheel	
7	Pin	
8	Dust cover	
9	Grinding head	<i>4.14 Changing tools</i>
10	Lifting handle	<i>3.3 Lifting</i>
11	Motor	<i>1.2 Mechanical specifications</i>
12	Connector motor - frame	
13	Control panel	
14	Handle	
15	Electrical cabinet	
16	Power inlet	
17	Dust collector connection	
18	Frame	
19	Dust hoses	
20	Wheels	
21	Gear barrel	
22	Dust cover	
23	Cover	
24	Lift handle	
25	Motor	
26	Cover	
27	Water tank	





Table 1-3 Machine parts overview

2 Safety Regulations



Read this entire chapter carefully! Failure to comply with safety regulations may result in serious injuries or damages.

2.1 Legend

	Notation regarding safety
	Notation regarding electrical safety
	Notation regarding safety during transport
	Tipping hazard
	See reference

2.2 Safety precautions



Any machine, if it is not used according the regulations, may be hazardous for operating, setting-up and service personnel. The operating authority is responsible for compliance with the safety regulations during operation and maintenance, and for the use of safety devices supplied with the machine, as well as the provision of appropriate additional safety devices!

Eye and ear protection must be worn at all times.

Never operate the machine when it's not in its upright position.

Make sure there is no debris in the work area.

Check the work area for screws or other hard objects in the concrete. Don't use the machine if there are any foreign objects stuck into the surface. Such objects must be removed prior to operation of machine.



Read “2.3 *Organizational measures*” and “2.5 *Safety regarding operation of machine*” thoroughly before operation!

2.3 Organizational measures



The user guide is to be kept near the location where the machine is being operated and must be within reach at all times.

In addition to this user guide general and legal regulations regarding accident prevention and environmental protection must be complied with as per local regulations.

Such duties may, for example, relate to the handling of hazardous substances, or to the provision and wearing of personal protection equipment, as well as compliance with traffic regulations.

The user guide must be supplemented by other instructions, including the duty to supervise and report incidents relating to particular working practices, for example work organization, work procedures and personnel safety.

Personnel entrusted with working with the machine must read the User Guide before starting work, in particular the “2 *Safety Regulations*” chapter. To read these instructions after work is commenced is too late. This particularly applies to incidental activities such as setting up the equipment, carrying out maintenance work or training staff to work with the machine.

From time to time the working practices of the operators are to be checked by a supervisor especially to the items regarding awareness of safety and hazards.

Operators must tie back long hair, and not wear loose clothing or jewelry including rings. There is a risk of injury through items getting caught, or being drawn into moving machinery.

Eye and ear protection must be worn at all times!

Use personnel protection equipment if necessary or required by local regulations! Take notice of all safety and hazard notices on the machine!

All safety and hazard notices at or on the machine must be kept complete and legible!

If safety-critical changes occur to the machine or its working method, the machine must be shut down immediately! The cause of the fault must be established, and rectified.

Changes, add-ons or conversion to the machine, which might impair safety, must not be made, without the manufacturer’s permission!

This applies in particular to the fitting and adjustment of safety devices.

Spare parts must comply with the technical requirements specified by the manufacturer. This is always guaranteed if original spare parts are used.

Intervals for recurring checks and inspections specified in this User Guide must be complied with!

To perform maintenance work correctly it is imperative to be equipped with the proper tools for the task in question.

Repairs may only be made by Scanmaskin Sweden AB certified service technicians.

Some grinding work may generate sparks under certain circumstances. Personnel working with the machine must therefore be aware of the risk of fire and how to handle a fire situation properly.

Do not use the machine in areas with highly flammable and/or explosive materials.

2.4 Personnel selection and qualification

Fundamental duties:

- Work with the machine may only be undertaken by trained personnel.
- Specify clearly the responsibilities of personnel for operation, setting up, servicing and maintenance work!
- Make sure that only authorized personnel operate or work with the machine!
- Define responsibilities of the machine operator, with regard to traffic safety regulations, and inform him not to take instructions from third parties who may not be complying with the local safety requirements.
- Personnel, who are being trained to operate equipment, may only use the machine under constant supervision of an experienced person!
- Work on electrical equipment may only be undertaken by a skilled electrician or by trained persons under the supervision of a skilled electrician, as well as in accordance with the local electrical engineering regulations.

2.5 Safety regarding operation of machine



Do not allow any method of working that impairs safety!

Recognized official procedures have to be used to ensure the machine is operated in safe and best conditions.

Only operate the machine when all safety devices and related safety equipment are present and operational!

Check the machine visually for any damage and defects at least once a day.

In the event of operational malfunctions the machine must be shut down immediately and secured!

Secure the work area around the machine in public areas providing a safety distance of at least 10 m (3.3 ft) from the machine.

Faults must be immediately rectified.

Carry out the switch on, and switch off operations in accordance with this user guide.

Before switching on the machine make sure that no-one can be endangered when the machine starts up.

Never operate the machine when not in its upright position.

Do not switch off or remove the exhaust and or the ventilation devices whilst the machine is running!

All persons in the proximity of the machine must wear ear and eye protection as well as safety shoes. In addition the machine operator must wear close-fitting protective clothing.

Only use extension cables that are sized and marked in accordance with the overall power consumption of the machine and the valid VDE guidelines.



See “2.6 Electrical safety” for further information.

Make sure there is no debris in the work area.

Check the work area for screws or other hard objects in the concrete. Don't use the machine if there are any foreign objects stuck into the surface. Such objects must be removed prior to operation of machine

2.6 Electrical safety



The power source must be equipped fuses according to the table in “1.1 Electrical specifications”. All cables used must be marked and rated according to the fuses used. Never connect the machine to a power source that does not provide protective earth!

Work on electrical equipment may only be undertaken by a skilled electrician or by trained persons under the supervision of a skilled electrician as well as in accordance with the local electrical engineering regulations.

Use only extension cables, that are used for extending the main cable, that are sized and marked in accordance with the overall power consumption of the machine and the valid VDE guidelines.

The electrical equipment for the plant must be inspected regularly. Defects such as loose connections or scorched cables must be rectified immediately. Call a skilled electrician or out customer services.

A second person must be in attendance whilst the electrical engineer is working on the equipment.

The work area must be secured against any third party entering the work area. Follow local electrical engineering regulations while working on the machine. Never leave a machine unattended. Use only tools that are insulated against electricity.

Only start work after you are familiar with the electrical engineering regulations that apply to the local area.

Only use voltage seekers that comply with the regulations when troubleshooting. From time to time check voltage seekers to ensure that they are operationally efficient.

2.6.1 Cables



Only use cables that are marked and rated according to the specifications in “1.1 Electrical specifications”. Don’t use excessive length of the cables. If a very long cable is needed we recommend that you use a cable rated for more current and connect it to a distribution central near the machine. Never lay the cable in a loop when operating the machine, this will cause the cable to heat up and may cause fire. See “Figure 2-1” for explanation.

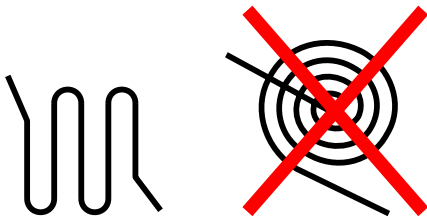

Figure 2-1 Recommended way to handle excessive cable length.

2.6.2 Using a generator



The generator must be equipped with protective earth and operated in accordance with the current EN-VDE directives (this applies to the protective earth conductor in particular) in order to ensure that all safety devices are functioning and eliminate possible damage to electrical components.

2.7 Definition of the “Safety off position”

The machine is in a safe condition where it cannot be any hazard.

How to set the machine in the Safety off position:

1. Switch off the machine
2. If a dust collector is used, switch it off
3. Wait for all drives to come to a complete stop
4. Disconnect the main power
5. Secure against unintended restart



Always disconnect the main power at the machine end to be able to prevent other persons from accidentally reconnect the main power while working on the machine.

2.8 Safety regarding maintenance

Set the machine into the Safety off position before beginning any work on the machine.



See “2.7 Definition of the “Safety off position””.

Never work on the machine while power is still connected!
All parts must have come to a complete stop before beginning any work!



When the machine is lying down on its back it might tilt to it's upwards position. Take extra care to prevent this from happening to ensure that no injuries or damages occur.



When the machine has been operated the segments, Scan-On plates and other parts on the gear barrel may be hot. Take extra care to prevent burn injuries.

Adjustment, servicing and inspection work on the period of time limits, specified in this User Guide as well as any information on the replacement or parts and equipment must be undertaken and/or complied with!

These activities may only be undertaken by qualified personnel.



The machine must not be connected to any power source while cleaning.



See “5.5 Cleaning the machine” for further information.

2.9 Safety regarding transport



Always remove the tools before transport. The tools may fall of or damage the surface the machine is transported along.

2.9.1 Manual transport



*When transporting the machine manually be observant about ramps and/or edges.
Follow local traffic regulations for the work site to prevent accidents. Failure to comply with these regulations may cause injuries or damages.*

2.9.2 Lifting



The machine must be secured according to local safety regulations before lifted.

No person is allowed beneath a lifted machine! The machine must be lifted according to the instructions in “3.3 Lifting”. Observe the machines point of balance before lifting! Failure to comply with these regulations may cause injuries or damages. Only use straps approved for the weight and circumstances!

2.9.3 Inside vehicles



Secure the machine according to local transport safety regulations before transporting the machine inside a vehicle.

3 Transportation

3.1 Safety precautions

 Read “2.9 Safety regarding transport” before attempting to transport the machine.

3.2 Manual transportation

- Detach the tools according to the instructions in “4.14 Changing tools”.
- Tilt the machine backwards.
- Push the machine in desired direction.

3.3 Lifting



Before attempting to lift the machine, read “2.9.2 Lifting”

- Detach the tools according to the instructions in “4.14 Changing tools”.
- Fasten the straps used for lifting at the two handles as shown in “Lifting points SC 450 Figure 3-2”.
- Lift the machine.

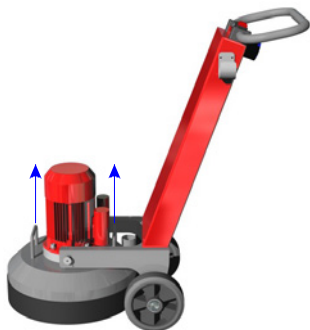

Figure 3-1 Lifting points SC 450

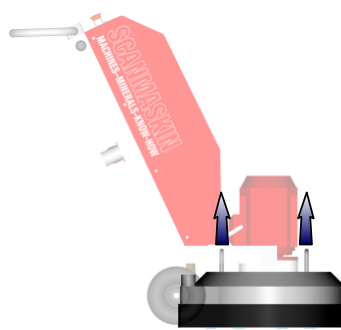

Figure 3-2 Lifting points SC 450 NS

3.4 Separation of machine

If the machine needs to be transported in a limited space it can be separated into two parts. On each side of the grinding head / motor assembly there is two pins, each fastened by a locking clip. To separate the machine, disconnect the motor cable; remove the locking clips and the pins. Take extra care to prevent the frame from falling backwards.

3.5 Inside vehicles

- Detach the tools according to the instruction in “4.14 Changing tools”.
- Secure the machine inside the vehicle.



Secure the machine according to local transport safety regulations before transporting the machine inside a vehicle. Failure to secure the machine may result in injuries or damages.

4 Operation

4.1 Precautions



Any machine, if it is not used according to the regulations, may be hazardous for operating, setting-up and service personnel. The operating authority is responsible for compliance with the safety regulations during operation and maintenance, and for the use of safety devices supplied with the machine, as well as the provision of appropriate additional safety devices!

Never operate the machine without proper tools.

Eye and ear protection must be worn at all times.

Never operate the machine when it's not in its upright position.

Make sure there is no debris in the work area.

Check the work area for screws or other hard objects in the concrete. Don't use the machine if there are any foreign objects stuck into the surface. Before operate the machine such objects must be removed.



Read "*2 Safety Regulations*" before operating the machine.

4.2 Machine functions

The gear barrel has got three grinding heads that rotates in the opposite direction of the gear barrel. Each grinding head is equipped with a Scan-on plate where each plate hold the tools used. See "*Figure 4-1*".



Figure 4-1 Illustrates the rotation of the grinding heads versus the gear barrel.



The machine is equipped with a thermal protection circuit that will shut down the machine in the event of high motor temperature. Wait at least 15 minutes before operating the machine again if this occurs.

4.3 Control device SC-450

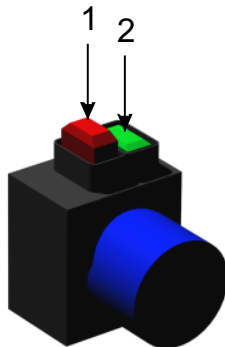

Figure 4-2 SC-450 control device

Item	Function	Description
1	Stop	Stops the SC-450
2	Start	Starts the SC-450

Table 4-1 Description of control device

4.4 Start up



See "4.1 Precautions" before starting the machine.

How to start the machine

- Make sure that the machine is equipped with the right "Scan on" tools.
- Make sure that the main power and hoses for the dust collector are connected to the machine.
- Turn on the dust collector if used.
- Push the handle downwards to lift the gear barrel about 10 cm (4") from the ground.
- Press the start button (2) on the control device.
- Lower the gear barrel down to the floor.
- Never let go of the handle during operation.

4.5 Stop

How to stop the machine

- Press the stop button (1)
- Wait until the machine comes to a complete stop before letting go of the handle
- If a dust collector is used, turn off

4.6 Control panel SC 450NS



Figure 4-3 Control panel of SC 450NS.

No.	Text	Description	Part number
1	L/R	Selects rotation direction	596001
2	SPEED	Selects speed ⁵	596009
3	EMERGENCY STOP	Emergency stop	596003
4	STOP	Stops the machine	596007
5	START	Starts the machine	596006

Table 4-2 Description of the control panel.

4.6.1 Water tank SC 450NS

 To increase the flow of the water turn the knob counter clockwise. The knob will move outwards.

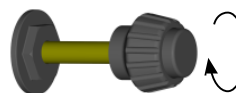
 To decrease the flow of the water, turn the knob clockwise. The knob will move inwards.

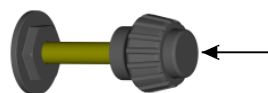
 To quickly stop the water flow, push the button on the knob. This releases the knob and a spring will pull it inwards.

 Secure the knob by tighten it slightly to ensure that no water will flow.

⁵ The range of the speed selection knob is described in "1.2 Mechanical specifications".

To empty the water tank before lying down transport, increase the water flow to a maximum and let the water pour out. Make sure the tank is empty before lying down transport.

Empty the tank before long time storage.

4.7 Start up the SC 450NS



See "4.1 Precautions" before starting the machine.

How to start the machine

- Make sure that the power plug and hoses for dust collector and water (if water supply is used) are connected to the machine.
- Turn on the dust collector if used.
- Push the handle downwards to lift the gear barrel about 10 cm (4") from the ground.
- Make sure that the "EMERGENCY STOP" is in its upper position.
- Press the "START" button on the control panel.
- Lower the gear barrel down to the floor.

4.8 Emergency stop / Reset SC 450NS

Use the Emergency Stop button to quickly stop the machine to prevent an accident or injuries.

Reset procedure:

- Turn the Emergency Stop button clockwise to release it
- Press the Stop button

The machine is now ready to be started again.

4.9 Stop the SC 450 NS

How to stop the SC 450NS machine

- Press the "STOP" button.
- Wait for the machine to come to a complete stop before letting go of the handle.
- Turn off the dust collector if used.

4.10 Grinding speed SC 450NS

Use the "SPEED" dial to adjust the rotation speed of the grinding discs between the intervals described in chapter 1.

4.11 Rotation direction SC-450 NS

Use the "L/R" switch to change direction of the grinding discs. The machine will first do a soft stop then a soft start.

4.12 Safety off position

When working on the machine, maintenance or tool change, the machine must be set to the “Safety off position”. See “2.7 Definition of the “Safety off position”” for further information.

4.13 Grinding

Refer to “Grinding guide” for instructions and information about grinding.

4.14 Changing tools



Before changing tools, read “2.8 Safety regarding maintenance”.

This illustration shows how to change the tools.

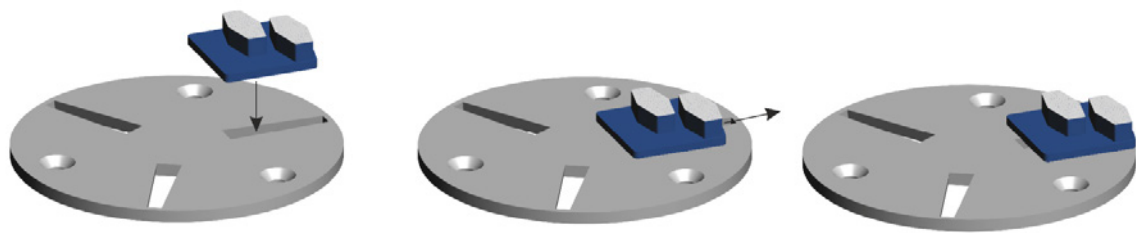

Figure 4-4 How to fit the diamond tools on the Scan-On plate

- Insert the segment at the widest part of the slot
- Push the segment outwards
- The segment is now fit on the Scan-On plate

To make sure that the tool is secured, use a small plastic hammer and slightly hit the tool outwards. In reverse this technique can be used to loosen tools that are stuck.

5 Maintenance

5.1 Precautions

Set the machine into the Safety off position before beginning any work on the machine.



See “2.7 Definition of the “Safety off position””.



Read “2.6 Electrical safety” before beginning any maintenance work.

Never work on the machine while power is still connected!

All parts must have come to a complete stop before beginning any work!



When the machine is lying down on its back it might tilt to it’s upwards position. Take extra care to prevent this from happening to ensure that no injuries or damages occur.



When the machine has been operated the segments, Scan-On plates and other parts on the gear barrel may be hot. Take extra care to prevent burn injuries.

Adjustment, maintenance and inspection work must be undertaken by qualified personnel.



The machine must not be connected to any power source while cleaning.

5.2 Daily inspection prior to operation

Inspect the following items prior to operation

- Inspect the wheels for damage.
- Inspect the grinding discs and hubs.
- Inspect the grinding head, dirt between the Scan-On plate and the grinding hub may lower the flexibility of the grinding head.
- If any screws appear loose, tighten them.
- Look over the machine for any other damage.

5.3 Maintenance and inspection list

Daily	<ul style="list-style-type: none"> ▪ Inspect the wheels ▪ Inspect the grinding heads ▪ Look for any other damage
12 hours after service	<ul style="list-style-type: none"> ▪ Tighten all screws

5.4 Grinding disc replacement / assembly

Follow these steps to replace the Scan-On plate

- Make sure the machine is in its “Safety off position”
- Tilt the machine backwards and secure it.
- Remove any tools used according to”4.14 Changing tools”.
- Loosen the three screws holding the Scan-On plate.
- Replace the Scan-On plate.
- It’s recommended that new screws are used to fasten the replacement Scan-On plate.
- It’s also recommended that copper paste is used on the surface of the screw hole at the Scan-On plate.
- Tighten all screws by hand and make sure that they are secured.

5.5 Cleaning the machine



Before starting to clean the machine, make sure it is in its”Safety off position”



The power must not be connected while cleaning the machine.

Do not use highly pressurized water to clean the machine.
Water and soap is recommended.

5.6 Trouble shooting

5.6.1 Common faults

Symptom	Cause	Correction	A ⁶
The machine won't start	<ul style="list-style-type: none"> ▪ There is a power failure from the power supply 	<ul style="list-style-type: none"> ▪ Inspect the fuses in the worksites fuse box ▪ Inspect cables ▪ Measure that all three phases are present and at full voltage near the machine 	O E E
The machine only operates while the start button is depressed	<ul style="list-style-type: none"> ▪ The motor is overheated 	<ul style="list-style-type: none"> ▪ Wait until the motor is cool again 	O
	<ul style="list-style-type: none"> ▪ The control device is damaged 	<ul style="list-style-type: none"> ▪ Replace the control device 	S
The machine is weak and might stop when on the ground.	<ul style="list-style-type: none"> ▪ There is a voltage drop at the power supply 	<ul style="list-style-type: none"> ▪ Inspect the fuses in the worksites fuse box ▪ Inspect cables ▪ Measure that the main voltage is present and at full voltage at the cable end near the machine. 	O E E
		<ul style="list-style-type: none"> ▪ Make sure that the cable is not too long. If the cable should be too long, use a cable with higher rating to a distribution box nearer the machine. 	O
The machine vibrates a lot	<ul style="list-style-type: none"> ▪ The grinding speed is to high 	<ul style="list-style-type: none"> ▪ Lower the speed 	O
	<ul style="list-style-type: none"> ▪ The tools are damaged 	<ul style="list-style-type: none"> ▪ Inspect the tools ▪ Change the tools if needed 	O O

5.6.2 Error codes SC-450 NS

Code	Description	Cause	Correction	A ⁷
A2001	Over current	<ul style="list-style-type: none"> One of the three phases is missing from the power supply There is a voltage drop at the power supply 	<ul style="list-style-type: none"> Inspect the fuses in the worksites fuse box Inspect cables Measure that all three phases are present and at full voltage at the cable end near the machine Make sure that the cable is not too long. If the cable should be too long, use a cable with higher rating to a distribution box nearer the machine 	O O E E
		<ul style="list-style-type: none"> The environmental temperature is too high. When the temperature is above 40°C (104°F) the inverter will decrease its maximum output current 	<ul style="list-style-type: none"> Inspect the ventilation fans Inspect the filters to the fans 	O O
A2002	Over voltage	<ul style="list-style-type: none"> The power supply has got voltage transients 	<ul style="list-style-type: none"> Inspect the power source 	E
A2003	Under voltage	<ul style="list-style-type: none"> One of the three phases is missing from the power supply There is a voltage drop at the power supply 	See A2001	
A2006	Speed reference error	<ul style="list-style-type: none"> The potentiometer on the control panel is damaged 	<ul style="list-style-type: none"> Inspect the potentiometer Replace if necessary 	S S
A2009	Over temperature	<ul style="list-style-type: none"> The internal temperature in the inverter is above 120°C (248°F). This could be caused by faulty ventilation in the electrical cabinet. 	<ul style="list-style-type: none"> Inspect the ventilation fans Inspect the filters to the fans Contact Scanmaskin Sweden AB 	O O
A5001	Internal error	Contact Scanmaskin Sweden AB		
F0001	Over current	See A2001		
F0002	Over voltage	See A2002		
F0003	Over temperature	<ul style="list-style-type: none"> The internal temperature in the inverter is above 135°C (275°F). This could be caused by faulty ventilation in the electrical cabinet. 	See A2009	
F0004	Short circuit in motor	<ul style="list-style-type: none"> The cable to the motor has been damaged The motor has been damaged 	<ul style="list-style-type: none"> Inspect the motor cable Inspect the motor connection Contact Scanmaskin Sweden AB 	E E
F0006	Under voltage	See A2003		
F0007	Speed reference error	See A2006		
F0016	Protective earth failure	<ul style="list-style-type: none"> The cable to the motor has been damaged The motor has been damaged Water have entered the motor 	<ul style="list-style-type: none"> Inspect the motor cable Inspect the motor connection Contact Scanmaskin Sweden AB 	E E
F0018	Internal error	Contact Scanmaskin Sweden AB		
F0021				
F0022	Power supply phase fault	See A2003		
F0034	Motor phase fault	<ul style="list-style-type: none"> One of the three phases to the motor is missing. This could be due to damage to the motor cable or to the motor. 	<ul style="list-style-type: none"> Inspect the motor cable Inspect the motor connection Contact Scanmaskin Sweden AB 	E E

Table 0-1 Error codes

Alarm codes starts with “A” and fault codes starts with “F”. The machine will be operational if an alarm code is present but not when an fault code is present.

The following table describes the access for the task.

Abbreviation	Person
O	Machine Operator
E	Electrician
S	Scanmaskin certified service technician

Table 0-2 Access rights for different persons

⁷ See access table ”Table 0-2”

6 Spare parts

6.1 Gear barrel

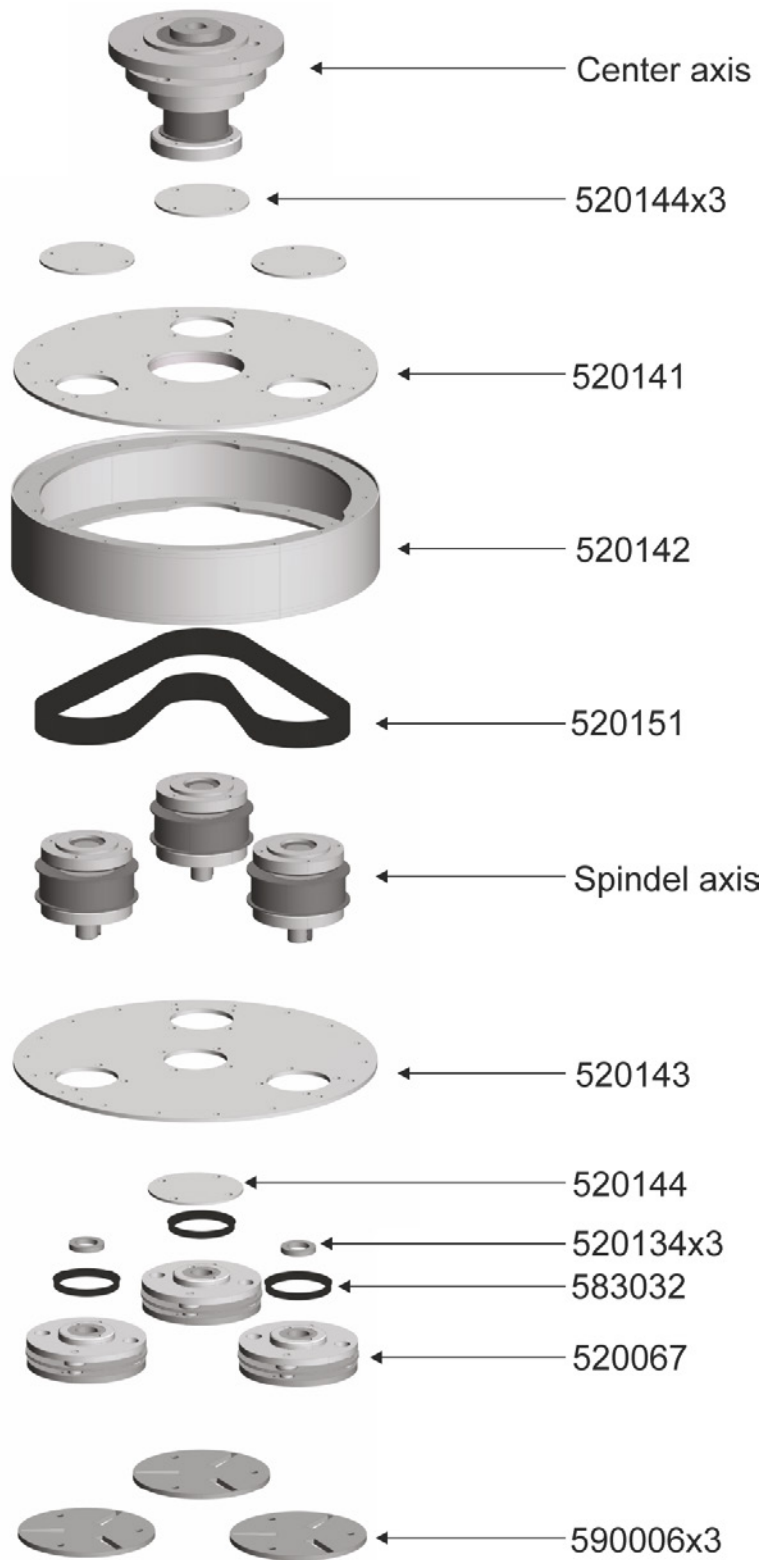

Gear barrel SC - 450	
520067	FLEX TOOL HOLDER SC-450/500/SM-18
520134	SPACER for AXLE, FLEX TOOL HOLDER, 18/450/500/650/700/800
520141	UPPER PLATE
520142	GEAR HOUSING
520143	LOWER PLATE
520144	COVER PLATE FOR BEARING BOX
520151	DRIVE BELT SC-450
583032	V-RING 65 FLEX TOOL HOLDER
590006	SCAN-ON FASTENING DISCS, SC-450/500/SM-18

6.2 Center axis

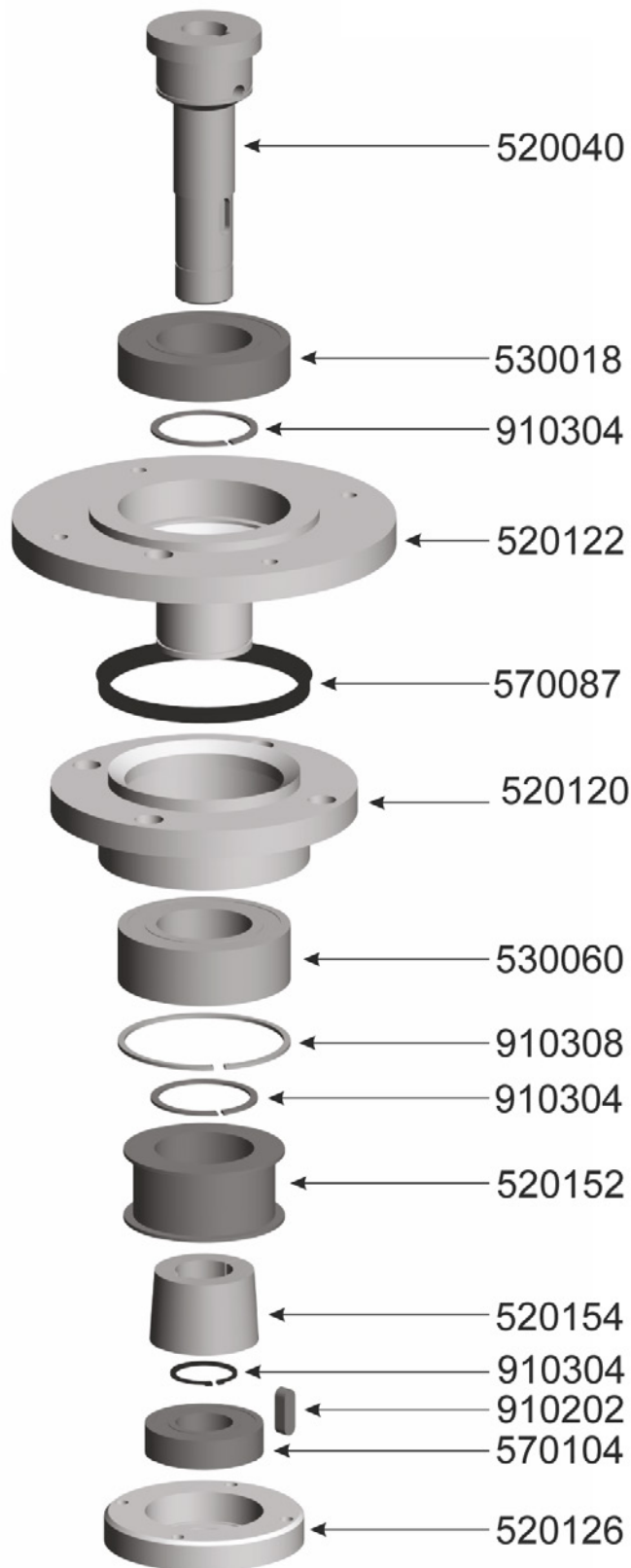

Center axis SC - 450	
520040	CENTER AXEL
520120	CENTRAL BEARING BOX
520122	UPPER ROTATING BEARING BOX
520126	BEARING BOX SM-18/450/500/650/700/800
520152	GEARWHEEL CENTRE (BL30-8M-30) SC-450
520154	TAPER LOCK FOR CENTRE GEARWHEEL (1615-30) SC-450
530018	BEARING 6210-RS1, SC-330/450/500/ SM-18
530060	BEARING 3210 2RS1 SC-450/500/SM-18
570087	V-RING V-100A SM-18/SC-450/500
570104	BEARING 6206 SM-18/SC-450/500/650/700/800/1000
910202	PARALLEL KEY 8x7x20
910304	CIRCLIP SGA 30
910304	CIRCLIP SGA 30
910304	CIRCLIP SGA 30
910308	CIRCLIP SGH 90

6.3 Spindel axis

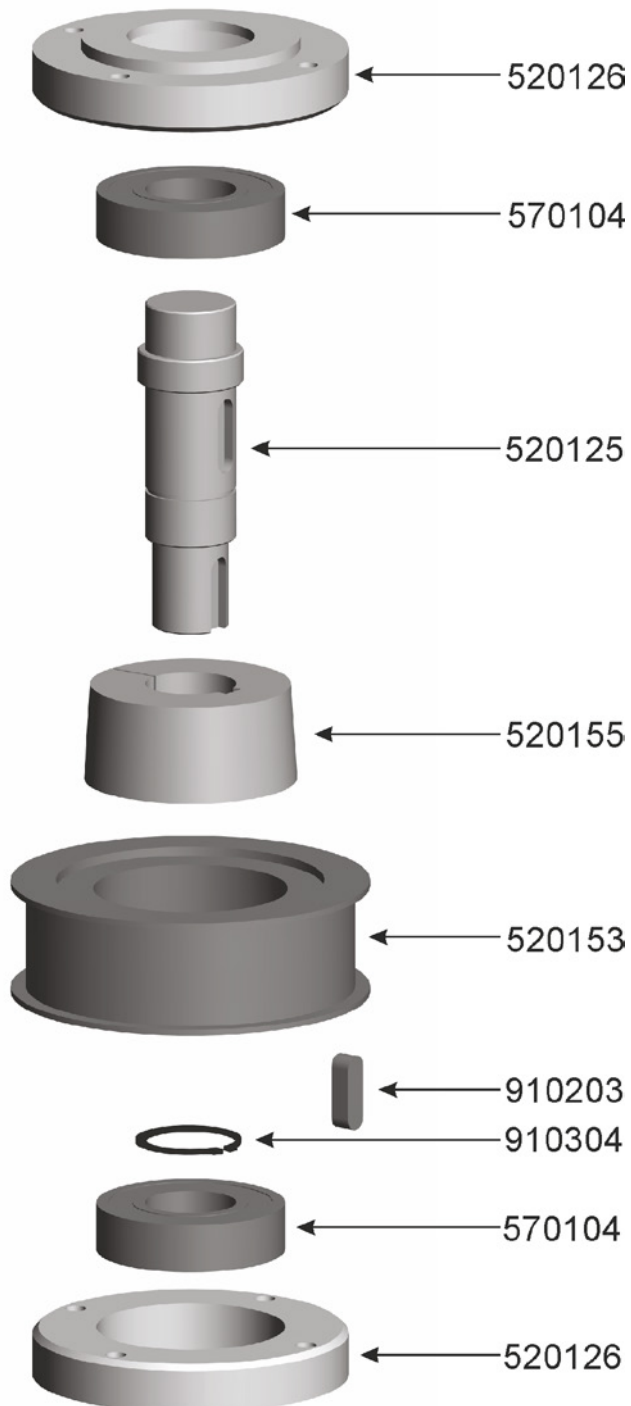

Spindel axis SC - 450	
520125	GRINDING AXLE SC-450/SM-18
520126	BEARING BOX SM-18/450/500/650/700/800
520126	BEARING BOX SM-18/450/500/650/700/800
520153	GEARWHEEL GRINDING AXLE SC-450
570104	BEARING 6206 SM-18/SC-450/500/650/700/800/1000
570104	BEARING 6206 SM-18/SC-450/500/650/700/800/1000
910203	PARALLEL KEY 8x7x25

6.4 Grinding head

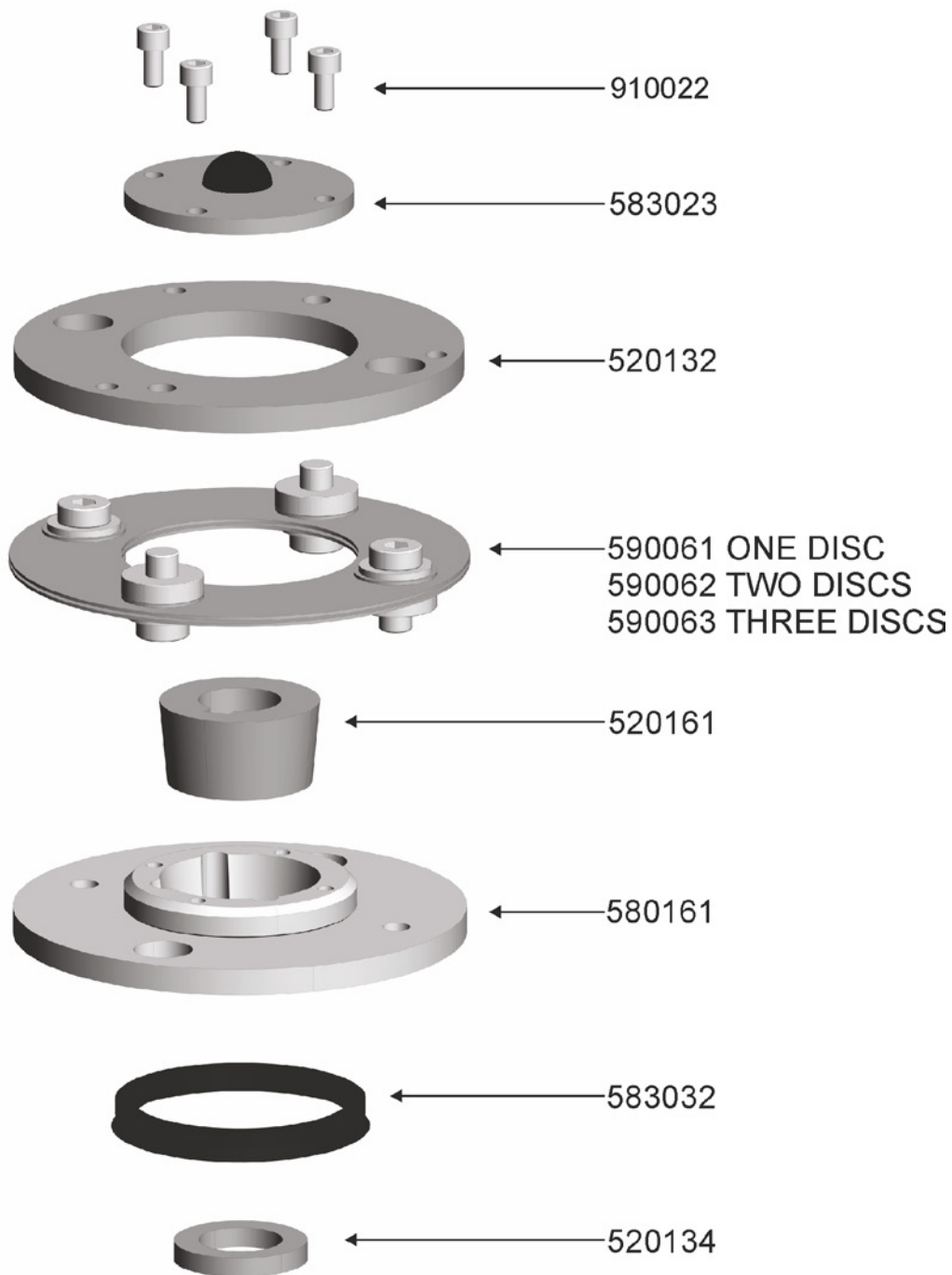

Grinding head SC - 450	
520132	LOWER FASTENING PLATE, FLEX TOOL HOLDER SC-450/500/SM-18
520134	SPACER for AXLE, FLEX TOOL HOLDER, 18/450/500/650/700/800
520161	TAPER LOCK BUSHING 25mm FLEX TOOL HOLDER, 18/450/500/800/
580161	CENTRAL HUB FLEX TOOL HOLDER
583023	COVER FOR CENTRAL HUB, FLEX TOOL HOLDER
583032	V-RING 65 FLEX TOOL HOLDER
590061	EXCHANGE KIT FLEX TOOL HOLDER (1 DISC)
590062	EXCHANGE KIT FLEX TOOL HOLDER (2 DISC)
590063	EXCHANGE KIT FLEX TOOL HOLDER (3 DISC)
910022	SCREW ALLEN KEY M6 x 12

7 Warranty

This product from Scanmaskin Sweden AB comes with a twelve month warranty. If the product does not function satisfactorily during this period, Scanmaskin will return the product to full working order for normal use which the product is intended for – with no charge for labor or spare parts, according to the following conditions:

1. The warranty only applies to persons that have legal right to the equipment during the warranty period.
2. The manufacturer's undertaking is limited to the repair of defective parts or the replacement of these according to the manufacturer's assessment. Costs and risks for transport as well as dismantling and reinstallation of the product / products and other direct or indirect costs, associated with the repair in question, are not covered by this warranty.
3. Periodic inspections, adjustments, maintenance work and changes are not covered by the warranty.
4. Scanmaskin is not liable for any damages to grinding discs or other similar equipment.
5. The warranty only applies to material and design deficiencies and does not apply in the following cases:
 - a. Damage caused through accidents, carelessness, changes, use of spare parts or grinding tools that are not original components, or incorrect use and installation.
 - b. Damage caused by lightning, water, fire, vandalism, incorrect mains voltage, incorrect ventilation or other causes that lie outside of the manufacturer's control.
6. Scanmaskin reserves the right to modify the design – or make improvements without obligation to change previously manufactured products.
7. All warranty repairs must be carried out by Scanmaskin or by a Scanmaskin authorized repair workshop. Costs for repairs, carried out by an unauthorized workshop, will not be reimbursed by Scanmaskin. If such repairs damage this product these are not covered by the warranty agreement.

8 EU Declaration

Declaration of CE conformity

Manufacturer Scanmaskin Sweden AB
Address Heljesvägen 10
427 36 Lindome / Gothenburg
Sweden

Product Grinding machine

Product name Scan Combiflex 450

Serial number _____

The product conforms with the following EU guidelines

Machine directives 2006/42/EG
EMC 2004/108/EG
LVD 2006/95/EG
Harmonized standards EN ISO 13850
EN ISO 12100-1/-2
EN ISO 60204-1

Location of issue Lindome / Gothenburg / Sweden

Authorized representative Claes-Göran Bergstrand
Managing Director

Scanmaskin Sweden AB
2010-01-01

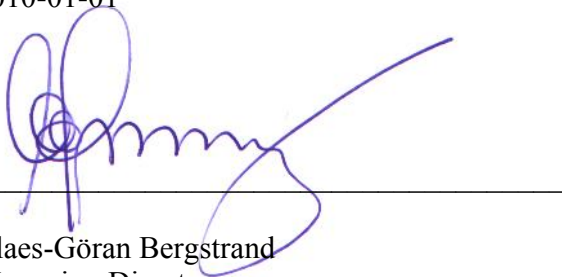

Claes-Göran Bergstrand
Managing Director

9 Alphabetical reference

C

Contact information	74
Control device	56
Control panel.....	57

D

Dimensions	
SC-450.....	41

E

Error codes	62
EU Declaration.....	72

F

Fuse	
External.....	40

I

Inspection	
daily	60
Maintenance and inspection list	60

M

Maintenance	
Access	62
Error codes	See Error codes

O

Overview	
SC-450.....	44

S

Separation of machine	53
Snap-On-plate	
replacing	61
Specifications	
Electrical	40
Start.....	56
Stop	56

T

Tools	
Available tools	42
changing	59
Transport.....	53
lifting.....	53
manual.....	53
Trouble shooting	
common faults.....	61

W

Warranty	71
Water	
tank.....	57

10 Contact information

Sweden (Head Office)

Heljesvägen 10
Box 187
SE-437 22 Lindome

Phone: +46 (0) 31 99 49 70
Fax: +46 (0) 31 99 48 70
E-mail: info@scanmaskin.se
Website: www.scanmaskin.se

Denmark

Torvegade 22
DK-7330 Brande

Phone: +45 97 18 00 58
Fax: +45 97 18 45 58
E-mail: info@scanmineral.dk
Website: www.scanmaskin.se

Norway

Postboks 6, Furuset
N-1001 Oslo
Tomtveien 12
NO-2015 Leisund

Phone: +47 63 87 60 00
Fax: +47 63 87 60 01
E-mail: info@scanmaskin.no
Website: www.scanmaskin.no

Finland

Raudoittajantie 3 A
FIN-06450 Porvoo / Borgå

Phone: +358 10 292 4700
E-mail: info@scanmaskin.fi
Website: www.scanmaskin.fi

USA

1407 132nd Avenue Northeast, Suite 8
Bellevue, Washington, 98005

Phone: +1 425 209 0147
E-mail: info@scanmaskin.com
Website: www.scanmaskin.com

SCANMASKIN

MACHINES—MINERALS—KNOW-HOW

SCANMASKIN SWEDEN AB

Huvudkontor / Head office

Box 187

SE-437 22 Lindome

Phone: +46 (0)31- 99 49 70

Fax: +46 (0)31- 99 48 70

Email: info@scanmaskin.com

Besöksadress / Visiting address

Heljesvägen 10

SE-437 36 Lindome

www.scanmaskin.com